

Portable Clean Room & Hood

MIDPOINT REPORT

Katie Hoffman

Daniel Marquez

Hannah Reed

2018-2019



Department of Mechanical Engineering

Northern Arizona University

Flagstaff, AZ 86001

Project Sponsor: Anevas Technology, Inc.

Faculty Advisor: Dr. Timothy Becker

Instructor: Dr. Sarah Oman

DISCLAIMER

This report was prepared by students as part of a university course requirement. While considerable effort has been put into the project, it is not the work of licensed engineers and has not undergone the extensive verification that is common in the profession. The information, data, conclusions, and content of this report should not be relied on or utilized without thorough, independent testing and verification. University faculty members may have been associated with this project as advisors, sponsors, or course instructors, but as such they are not responsible for the accuracy of results or conclusions.

EXECUTIVE SUMMARY

The objective of the clean hood project, proposed by Anevas Technology, Inc, is to design and build a portable clean hood, to fully design a portable clean room, and manufacture the clean room frame. The project is overseen by the client/faculty advisor Dr. Timothy Becker who leads the Bioengineering Devices Lab, affiliated with Mechanical Engineering and the Center for Bioengineering Innovation (CBI). The client needs a 72"x96"x84" clean room to perform training and testing with microcatheters and is also in need of a 24"x48"x40" clean hood to run small equipment under, specifically the client's rheometer. The primary requirements given by the client are that both units maintain a positive pressure, be portable, easily transportable, and produces a foreign particle clean environment.

The portable hood will be constructed of three separate pieces consisting of a hollow aluminum frame, a polycarbonate viewing case, and a Fan Filter Unit (FFU). The aluminum frame will support the total weight of the FFU, this will be to prevent the polycarbonate from fracturing or cracking. The aluminum frame will fit over the polycarbonate viewing window and seal the FFU to the viewing window. There will be a rubber seal that will prevent pressure loss between the three components. The polycarbonate viewing window will have a hinged door that creates access to the client's product being tested, and to adjust the rheometer that will primarily be operated within the hood.

The portable room will be compiled of four main parts, this includes a powder coated steel framing, the plastic lining and the two FFUs. The powder coated steel framing for the room will disassemble, by separating into smaller components, this is to simplify set up, allow portability and to lower the total amount of parts. Attached to the framing will be a detachable plastic lining, this creates visibility into the room and maintains the positive pressure. The plastic lining will be attached to the aluminum framing with 3M Dual Lock, that acts like Velcro, but is much stronger and can hold more weight. It was determined that two fans would be required to maintain a clean environment in the room. The room will primarily be used to preform tests utilizing a microcatheter in a semi-sterile environment. The clean room and hood will both create a clean environment on the FFUs lowest setting, allowing for additional cleanliness by turning up the speed of air flow.

Analytical calculations show the clean room and hood will maintain positive pressure with two fan units for the room and one for the hood. The structural analysis performed shows that the framing for the room will not fail under the load of both the FFUs resting on top. The fan filter analysis showed the maximum cleanliness classification the room and hood can sustain, along with indication for when the filters need to be changed. Calculations having been completed, the team moves to building and testing the clean room and hood.

TABLE OF CONTENTS

Contents

DISCLAIMER	ii
EXECUTIVE SUMMARY	iii
TABLE OF CONTENTS	iv
1 BACKGROUND	1
1.1 Introduction	1
1.2 Project Description	1
1.3 Original System	1
2 REQUIREMENTS	2
2.1 Customer Requirements (CRs).....	2
2.2 Engineering Requirements (ERs).....	2
2.3 Testing Procedures (TPs).....	3
2.3.1 Area.....	3
2.3.2 Pressure	3
2.3.3 Cost	3
2.3.4 Weight	4
2.3.5 Assembly Time	4
2.3.6 Power FFU	4
2.3.7 Particle Count.....	4
2.3.8 Velocity	4
2.3.9 Material.....	4
2.4 House of Quality (HoQ)	4
3 EXISTING DESIGNS	5
3.1 Design Research	5
3.2 System Level	5
3.2.1 Existing Design #1: Vertical Laminar Flow Hood	5
3.2.2 Existing Design #2: Horizontal Laminar Flow Hood	6
3.2.3 Existing Design #3: NCI 8’x8’x8’ Portable Clean Room	6
3.2.4 Existing Design #4: Clean Air Products 6’x8’x8’ Portable Clean Room.....	7
3.3 Functional Decomposition.....	8
3.3.1 Black Box Model	8
3.3.2 Work Process Diagram.....	8
3.3.3 Functional Model	9
3.4 Subsystem Level.....	10
3.4.1 Subsystem #1: Fan Filter Unit (FFU).....	10
3.4.2 Subsystem #2: Portable Clean Room.....	10
3.4.3 Subsystem #3: Portable Clean Hood.....	11
4 DESIGNS CONSIDERED	12
4.1 Portable Hood Designs	12
4.1.1 Design #1: Portable Hood with Exterior Frame.....	12
4.1.2 Design #2: Slide on External Frame Clean Hood	12
4.1.3 Design #3: Vertical Laminar Flow Hood with Solid Frame.....	13
4.1.4 Design #4: Horizontal Laminar Flow Hood with no Frame	14
4.2 Portable Clean Room Designs	15
4.2.1 Design #5: Clean Room with Detachable Frame	15
4.2.2 Design #6: Double Flap Clean room.....	16

4.2.3	Design #7: Portable Clean Room Single Flaps	17
5	DESIGN SELECTED – First Semester.....	19
5.1	Rationale for Design Selection	19
5.2	Design Description	20
5.2.1	Engineering Calculations	20
5.2.2	Model Drawings.....	20
6	PROPOSED DESIGN – First Semester	23
6.1	Implementation of Design	23
6.2	Bill of Materials.....	23
6.3	Final Design Assembly View and Exploded View	23
7	IMPLEMENTATION	25
7.1	Manufacturing	25
7.2	Design Changes	28
8	CONCLUSION	30
9	REFERENCES	31
10	APPENDICES	32
10.1	Appendix A: House of Quality.....	32
10.2	Appendix B: Portable Hood with Adjustable Frame.....	33
10.3	Appendix C: Portable Hood with Tabbed Framing.....	33
10.4	Appendix D: Technical Analysis.....	33
10.5	Computational Fluid Dynamics Analysis – Fluid Visual Representation	47
10.6	Appendix E: Bill of Materials	48
10.7	Appendix F: Gantt Chart.....	48

1 BACKGROUND

1.1 Introduction

The clean hood project was created by Aneuvus Technology, Inc and is overseen by Dr. Timothy Becker. The project objective was to design and build a portable clean hood, fully design a portable clean room and manufacture the frame for the room. The clean room and hood are to produce and maintain a positive pressure, which will reduce the number of foreign particles in the structures. This makes a clean environment for which the sponsor can conduct sterile experiments and test in. The company manufactures and analyzes minimal invasive microcatheter medical devices, used to treat aneurisms and other vascular defects in the brain. This project will benefit the client's research and development of their products by producing a clean low particle count environment.

1.2 Project Description

Following the original project description provided by Aneuvus Technology, Inc.,

“The scope of this project is to design, build, and test a fan-filter unit (FFU), a curtain clean room area, and a laminar flow hood to help establish sterile manufacture capabilities. The flow hood (2'x 4') and clean room (4'x 6') must have the ability to be disassembled and reassembled, clean and sterilized, and portable.”

The flow hood is to be 24"x 48"x 40" so it can fit over small equipment within the client's lab, along with an FFU placed on top of the frame to induce a positive pressure of clean air. The clean room has been changed to be 72"x 96"x 84" and will be fully designed and include the manufacturing of the steel frame per clients request. It must have the ability to be assembled, disassembled, and carried by 3-4 people; it will have two FFUs placed on top of the frame which will produce a positive pressure of clean air within.

1.3 Original System

This project involved the design of a completely new portable clean room and clean hood. There was no original system when this project began.

2 REQUIREMENTS

The requirements of this project include the customer requirements and the engineering requirements. The customer requirements were provided directly from the client/sponsor. The engineering requirements are derived from the customer requirements using the House of Quality (HoQ) and were given a unit of measurement and a targeted value. Then the engineering requirements are put through a testing procedure (TPs) to verify if the customer requirements were met.

2.1 Customer Requirements (CRs)

The customer requirements were obtained during the first client meeting and from the project description they are listed below.

Table 1: Customer Requirements

Customer Requirements	Weight	Objective
Inexpensive	5	Maintained a controlled clean environment
Portable	3	Low cost and remain within budget
Positive Pressure	5	Meet FDA classification requirements of number of particles in the air per cubic meter
Visibility	2	Ability to see inside the structures
Clean	4	Maintain an ISO classification
Reliability	3	Reassurance that the structure will not fail
Durability	3	Last for an extended period of time
Noise	4	Low emission of noise from FFUs

2.2 Engineering Requirements (ERs)

From the customer requirements, engineering requirements were compiled to meet the CRs and are listed below. The different parameters used for the technical terms are given by Table 2. Measuring the area of both the hood and the room is in terms on m^2 . The second parameter would be the pressure for each room and is measured in pascals. Also identifying the total potential cost for the room and the hood which is denoted in dollars. An important factor for the ability to transport both the hood and the room is the assembly time which is in minutes. The power generated for both systems is denoted by watts. The velocity for each fan unit will be measured in $\frac{m}{s}$ which will be used to understand positive pressure through the system. The overall sounds coming from each system will also be taken into consideration, this will be measured in decibels and the stress factors within the frame while holding the fans will be measured in pascals.

Table 2. Engineering Requirements

Engineering Requirements (Units)	Hood Targets	Room Targets
Area (m ²)	< 0.557	< 3.62
Pressure (Pa)	>78000	>78000
Cost (\$)	<2000	<2000
Weight (kg)	< 45.36	< 54.43
Assembly Time (min)	<10	<30
Power FFU (W)	520	1040
Particle Count (per m ³)	<102,000	<102,000
Velocity FFU (m/s)	>0.58	>0.58
Material	N/A	N/A
Sound FFU (dBa)	<50	<50

2.3 Testing Procedures (TPs)

This section discusses the testing procedures considered to verify each customer requirement has been met.

2.3.1 Area

To test the area of both units we will measure each side 2-3 times with a tape measure for accuracy and then calculate the area with the dimensions measured. The tape measure is previously owned by a team member.

2.3.2 Pressure

To measure the pressure within each unit we will obtain a pressure DAC and 7 pressure transducers which will connect to a computer with the program LabVIEW set up. The pressure inside the units and the atmospheric pressure outside are to be measured in each unit built. The measurements from the transducers is carried to a DAC which takes the data and transfers it to the computer. The computer has a program LabVIEW which interprets and records the data collect by the transducers and DAC. Then LabVIEW takes the data and converts it to a readable pressure measurement. Three readings will be conducted at seven different locations within the hood and room. One measurement 6” below the FFU, a measurement at the bottom of the unit, on all four walls, and outside the unit. By measuring each location 3 times ensures accuracy. The testing equipment will be obtained through the client, Dr. Becker.

2.3.3 Cost

To verify that the cost is met, we will update and evaluate the given budget and bill of materials together. This will verify the budget is met, below, or exceeded.

2.3.4 Weight

The weight of both units will be estimated with the program Solidworks because they are too large to fit onto any scale. Northern Arizona University has access to Solidworks for students.

2.3.5 Assembly Time

A timer will be used to measure how long it takes to assemble each unit separately and then the disassembly of each unit.

2.3.6 Power FFU

To test if the FFU has power will be done by plugging in the unit and turning it on. The power of the fan filter unit at its lowest setting is 393 Watts [2].

2.3.7 Particle Count

Due to budget constraints a particle counter could not be obtained to count the particles within each unit. To obtain an estimation of particles within each unit, the information is based from the manufacturer, the HEPA filter, and the size of the room vs the number of FFUs.

2.3.8 Velocity

From the pressures measured and tested with the pressure transducer the velocity can be calculated by using the pipe flow energy equation. The velocity of the FFUs are given by Terra Universal and each unit outputs about 0.4724 meters per second as seen in Appendix D.

2.3.9 Material

The material will be tested first through hand calculations and then with Solidworks software to verify the material and design. Then once the design is manufactured, we will test the material by placing the FFUs on both units to see if the structures can withstand the weight and location of the fan units. The FFUs are purchased through the manufacturer Terra Universal [2].

2.4 House of Quality (HoQ)

The House of Quality, as seen in Appendix A, relates and compares the customer requirements to engineering requirements, to meet the client's expectations and desires for the project. The HoQ gives a visual of ERs that have greater importance or higher scores in relation to the ranked CRs. Each ER is given a specific target value that will allow for the design to meet the client's needs. In Table 1, the results of the weighted CRs are from the quality function deployment (QFD) chart, as seen in Appendix A, the positive pressure and inexpensiveness were weighted the heaviest because they were emphasized the most by the client. While visibility was weighted the lowest because the given material is already transparent. In Table 2 the scoring of the ERs was from Appendix A, the pressure and number of particles had the highest score of 13. While the lowest scored ER was sound with a score of 1.4. Each customer requirement was obtained by the project description as well as the client. The results from the HoQ allowed the team to prioritize the CRs and ERs needed to successfully complete the design and fulfill the client's desires.

3 EXISTING DESIGNS

This section covers the design research, system level, functional decomposition and the subsystem level. Research was conducted to obtain a better understanding of portable clean rooms and hoods, their classification, the FFUs, and the type of material used for them. There are a variety of different designs for both units, most clean rooms and hoods have similar features but key differences. Most clean rooms have clear walls for manufacturing visibility purposes, as well as two FFUs that provide positive pressure in the room. Clean hoods can be either a vertical laminar flow or a horizontal laminar flow with clear walls to direct the flow out through the opening. Another difference is the functionality of the room, most portable clean rooms have casters allowing movement. These existing designs aided in the process of design concept generations for the hood and room, suiting the client's needs.

3.1 Design Research

There are many designs and concepts of portable clean rooms and hoods. Various companies were found through online research, that manufacture portable clean rooms and hoods. There are two types of clean hoods: vertical laminar flow and horizontal laminar flow. Clean Air Products and Terra Universal are the top two manufacturers out of many that were researched and analyzed. The vertical and horizontal hood designs were reviewed to verify that both meet the CR criteria. The vertical flow hood has an FFU placed on top which then produces a vertical flow of air downward. The horizontal flow hood has an FFU placed at the back of the hood blowing a horizontal flow of air towards the front. For portable clean rooms there are two styles, a soft-walled and a hard-walled clean room. The hard wall clean room can be both a permanent and portable room with hard walls all around. The soft wall clean room is primarily a portable based room with soft clear walls all around. All existing designs can be seen in the sections below. These designs were evaluated to justify which concept best suited the client's conception.

3.2 System Level

There are a few existing designs that represent potential design concepts for this project. The clean rooms available with similar design requirements pertaining to this project are sold by various companies around the US. The requirements for most clean rooms are similar, they involve creating a laminar air flow and producing positive air pressure to prevent particles from accumulating. Clean rooms vary in ISO classification which pertain to the number of particles per cubic area. Each clean room has different standards given the fan utilized, and these standards vary from 10,000 particles per cubic area to 100,000 particles per cubic area. Existing designs like a vertical laminar flow would be useful to create a clean room over a work area. Where a horizontal laminar flow hood is practical for some applications, pushing the flow towards the user, but for this project it would not suit the client's needs.

3.2.1 Existing Design #1: Vertical Laminar Flow Hood

As seen in Figure 1 below, this hood produces a vertical laminar flow of clean air over the work space. This design is an ideal concept to analyze because it meets most of the CRs needed to satisfy the customer. It produces positive pressure, clean air, durable, reliable, and portable. It does not meet the cost or visibility requirement that the client requests.



Figure 1. Vertical Laminar Flow Hood [4]

3.2.2 Existing Design #2: Horizontal Laminar Flow Hood

The horizontal laminar flow hood, as seen in Figure 2, produces a horizontal laminar flow. This design meets some of the requirements but is not the best design to analyze because the FFU is located on the back side of the hood. This design does not follow the client’s specifications, which was having the FFU on the top of the hood due to limited surrounding space. Overall, a great perspective but does not meet the CRs entirely.

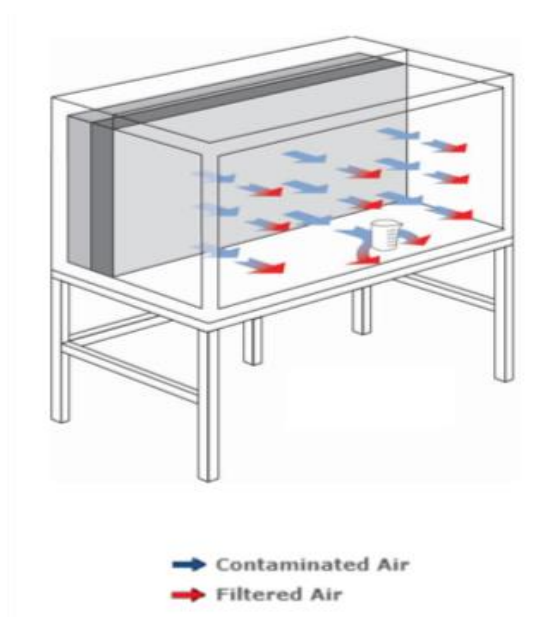

Figure 2. Horizontal Laminar Flow Hood [4]

3.2.3 Existing Design #3: NCI 8’x8’x8’ Portable Clean Room

NCI created a clean room, seen in Figure 3, that fulfills most of the customer requirements needed for the clean room project. This portable clean room exceeds the size needed for the project but is portable. The

main concern for this portable clean room was if it could be carried by three to four people, as specified in the CR's. Due to the size of this clean room created by NCI, it may not meet the requirement of portability for the clean room project. Nevertheless, the design can be used for creative idea generation for the final design concept of the clean room.

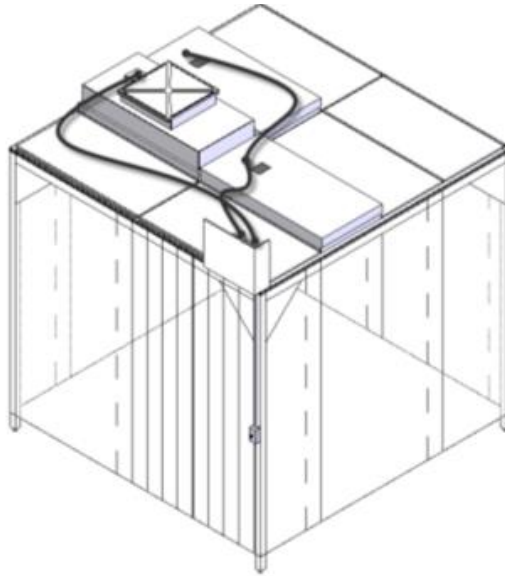

Figure 3. 8'x8'x8' Portable Clean Room [3]

3.2.4 Existing Design #4: Clean Air Products 6'x8'x8' Portable Clean Room

In Figure 4, Clean Air Products created a portable clean room fulfilling some of the requirements our client requested be met. The dimensions exceed the required size needed, but it does meet the engineering requirement of being portable. The size of the room is important since it will be used in different sized areas. The concept of this clean room could be used as reference, since it meets some of the customer requirements needed for the clean room project.



Figure 4. 6'x8'x8' Portable clean room [1]

3.3 Functional Decomposition

The functional decomposition breaks down the entire system into smaller components. For this system a black box model and a functional model were created to obtain a better understanding and to simplify the project into smaller sections. These sections incorporate the basic principles of the black box and expand on it. Tracking the different flows like material, energy, and signal to create a logical flow of the processes going on within the system. The functional model takes the black box model and applies it to each unit and elaborates in detail.

3.3.1 Black Box Model

The black box model, Figure 5, portrays a simple overview of the inputs and outputs of positive pressure in a structure. The three flows through the hood and the room are a material flow, energy flow, and signal flow. For material flow, cleaning the room and utilization of the user's hands are expanded upon and create a flow of materials in and out of the system. Energy flow was a section of interest since it creates the main functionality of the clean room. The fans capture the kinetic energy coming from the clean room then releases it as laminar air flow which creates the positive air pressure. The electrical energy is used to power the fans which then engages the fans functionality. Human energy is introduced during system operation and when humans are operating within the system. Signal flow is used to indicate whether the system is under operation and this allows the user to understand whether the clean room is on or off.

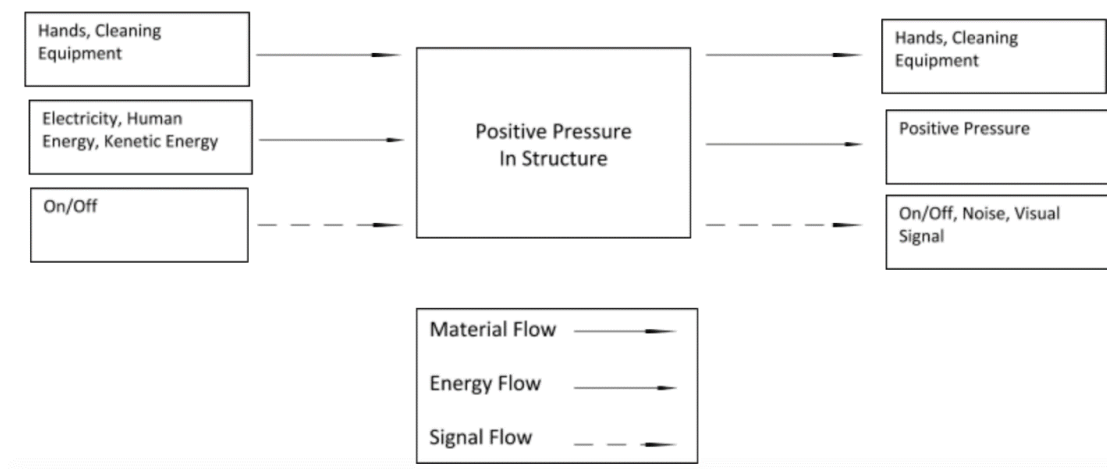

Figure 5. Black Box Model

3.3.2 Work Process Diagram

The work process diagram shows the hierarchical type work needed to create the clean room as proposed by the customer. It starts with the project description, then ideas are generated for the project. Research was conducted using journals, the internet, and companies to obtain a better understanding of clean environments and aided in design concept generation. Proposed design concepts were compared by the team, presented to the client and iterated until the design shapes to the clients ideal perception. Once approved, possible prototypes of the design were then created. A final cost analysis and design concept was created and presented to the client for final decision making. Thus the work process diagram was created and shown in Figure 6.

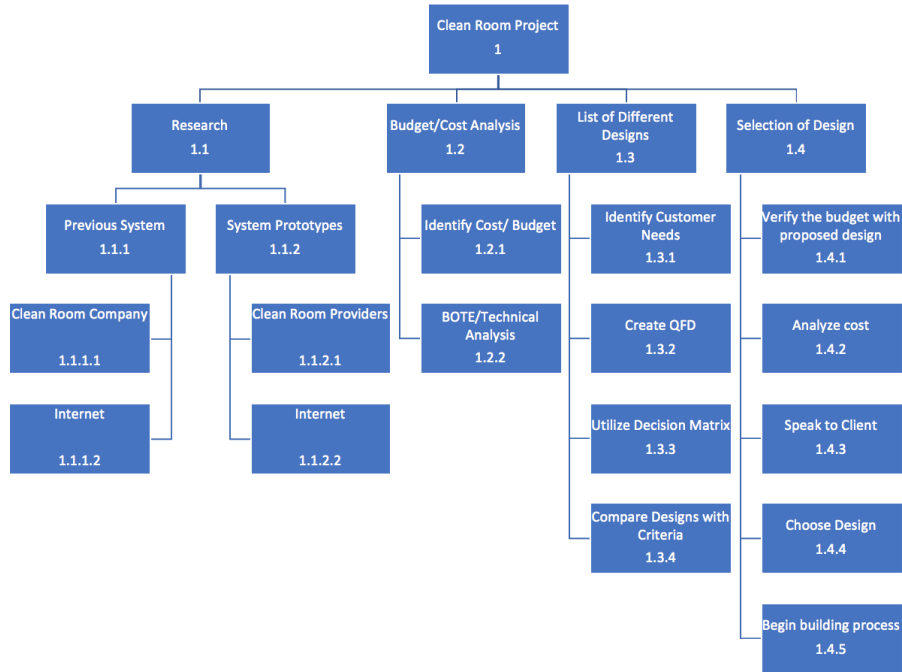

Figure 6. Work Process Diagram

3.3.3 Functional Model

The functional model is a breakdown of the process taken to achieve a successful clean room and hood. As seen in Figure 7, there are various broken-down steps that give a layout of what needs to be completed to obtain a successful finished project.

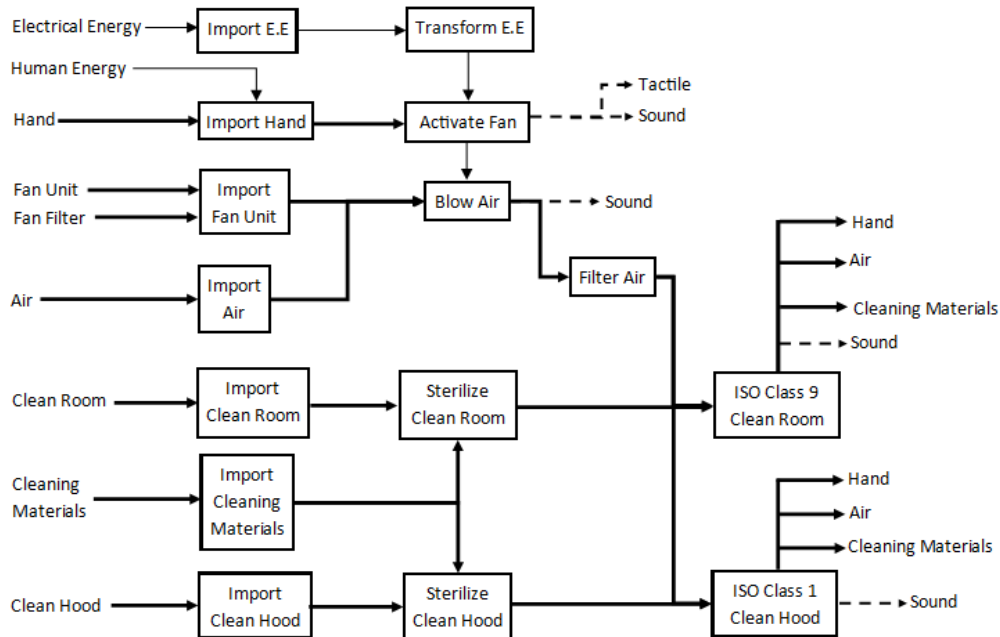

Figure 7. Functional Model

3.4 Subsystem Level

The subsystem shows the pre-existing designs that are currently being used by different clean room providers. The clean rooms relevant to this project will follow a set of customer requirements. The first requirement is portability. For the portable hood, it must be carried by a maximum of 2 people and for the portable clean room it must be carried by a maximum of four people. The other requirement is that each room must create positive air pressure within the system. For the clean hood one of the requirements is a specific plastic that is to be incorporated within, which is polycarbonate.

3.4.1 Subsystem #1: Fan Filter Unit (FFU)

An FFU is the most important component to the project. Fan filter units are what induce positive pressure and produce a clean environment for the portable hood and room. These designs are pre-existing and have been used through industry for all aspects of rooms and hoods.

3.4.1.1 Existing Design #1: WhisperFlow, 2' x 4', HEPA, 120, Powder-Coated Steel

This FFU is manufactured by Terra Universal [2]. The unit is a 2'x4' powdered-coated steel, with a HEPA certified filter at the bottom and weighs about 71lbs. The unit is designed to produce a positive air pressure and filtered clean air for both units. The level of cleanliness is also based on the size of the room and how many FFUs are needed to meet the rooms requirements. This FFU is design for an ISO classification down to a class 10.

3.4.1.2 Existing Design #2: Motorized Ceiling Fan Filter Unit CAP118

This FFU is manufactured by Clean Air Products [5]. The unit is a 2'x4' galvanized steel, with a HEPA certified filter at the bottom, and weighs about 80lbs. This FFU is design for an ISO classification of class 10. The FFU is designed to obtain positive pressure and produce filtered clean air.

3.4.1.3 Existing Design #3: FFU – Fan Filter Unit Price Industries

The fan filter unit is manufactured by Price Industries [3]. The FFU is a 2'x4' the material is aluminum and steel, with a HEPA filter, and weight ranges from 66-76 lbs. The ISO classification is for class 10. The fan filter unit is designed to produce filtered clean air and positive pressure within the units.

3.4.2 Subsystem #2: Portable Clean Room

There are many portable clean rooms, client requirements specify and narrow the team's choices. The clean room was required to be lightweight and to have the ability to be transported with a max of four people. The clean room must meet a specific dimension based on the size of room described by the client, and the ability for three people to work within the clean room. There were three subsystems evaluated and analyzed.

3.4.2.1 Existing Design #1: Clean Air Product's Softwall Clean Room

An existing design researched and analyzed was manufactured by Clean Air Products [1]. A soft wall design has also been used by different clean room providers. The softwall designs are transparent walls that allow easy visibility to the atmosphere inside the room. A soft wall implemented within the project would help meet the requirement of being lightweight.

3.4.2.2 Existing Design #2: Clean Air Products Hardwall

This subsystem provides a better support than the softwall, but visibility will be compromised due to the structural walls. The hardwalls will improve the overall safety of the clean room by providing a more robust and durable material to withstand the different forces that the room is being subjected to. The hardwall room analyzed was manufactured by Clean Air Products [13].

3.4.3 Subsystem #3: Portable Clean Hood

This subsystem shows a room that can be easily transported within rooms. Clean room providers have created a clean room that is both portable, but also has see-through walls. This room was important because the subsystem could be implemented for the clean room project.

3.4.3.1 Existing Design #1: Vertical Flow Hood

This hood produces a vertical laminar flow of clean air over the work space. The design was an ideal concept to analyze because it met most of the CRs needed to satisfy the customer. It produces positive pressure, clean air, durable, reliable, and portable. This design was manufactured by Terra Universal [4].

3.4.3.2 Existing Design #2: Horizontal Flow Hood

The horizontal laminar flow hood produces a horizontal laminar flow analyzed from the manufacture Terra Universal [4]. This design meets some of the requirements but was not an ideal design to analyze because the FFU was located on the back side of the hood. The design does not follow the client's specifications, which was having the FFU on the top of the hood due to limited surrounding space. Overall, a great perspective but did not met the CRs entirely.

4 DESIGNS CONSIDERED

This section describes the designs considered for selection of the final design. The section was broken up in to designs for the portable hood and designs for the portable clean room. Overall, it was difficult in considering designs because of the many restrictions through the client, FDA, and HEPA which limited the designs.

4.1 Portable Hood Designs

Below are concept designs for portable clean hoods.

4.1.1 Design #1: Portable Hood with Exterior Frame

Using an outer skeleton as a frame reduces the strain on the polycarbonate walls of the room. The frame was to hold the FFU and was to be sealed with the help of an adhesive which can be removed easily. The frame was to be made from aluminum which reduces the weight of the overall clean room. This helps with the ease of transportation which was required by the customer. The polycarbonate walls have an entrance point that is 6"x12" which was required for working within the station. A negative about the device was the opening which was to be a hinge style opening which may reduce the visibility of the user when working. Another con was that the outer frame can also decrease the visibility when looking through the sides of portable hood.

Table 3. Pros and Cons of Portable Hood with Exterior Frame

Cons	Pros
Bad visibility due to frame	Lightweight
Bad visibility due to hinge opening	Clear Panels
Expensive material	Ease of work within clean room

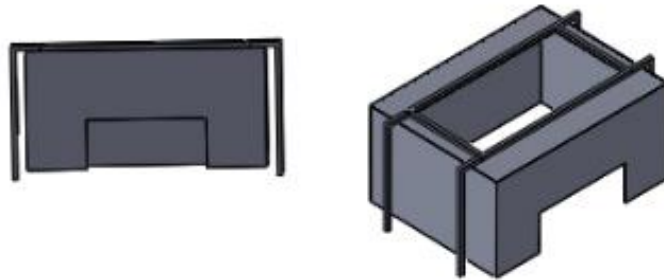

Figure 8. Design for Portable Hood with Exterior Frame

4.1.2 Design #2: Slide on External Frame Clean Hood

The design shown in figure 9 contains two parts, plus the FFU. The design was made so the rubber feet on the bottom of the polycarbonate hood can sit on the feet of the metal structure, this creates less movement of parts. The doors hinged on the polycarbonate structure open to the sides, rather than above, this removes the need for magnets or a latch to keep the door open while working. The metal frame has tabs that help to hold the FFU in place, rather than having the weight of the FFU sitting on the polycarbonate directly, this reduces the thickness of the polycarbonate and therefore reduces the price of the polycarbonate.

Table 4. Pros and Cons of Slide on External Frame Clean Hood

Cons	Pros
Expensive materials	Lightweight
Thin polycarbonate	Low number of parts
Large components	Durable design
Hard to move	Simple construction

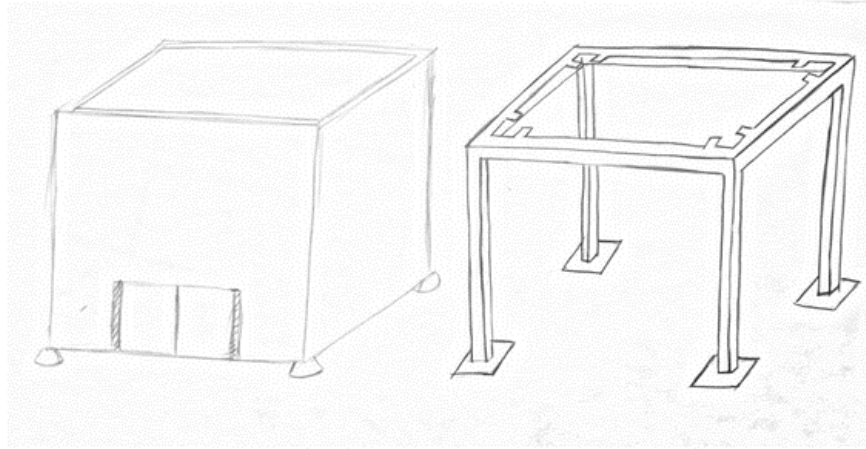

Figure 9. Design for Slide on External Frame Clean Hood

4.1.3 Design #3: Vertical Laminar Flow Hood with Solid Frame

The vertical laminar flow hood designed in figure 10 has a separate aluminum frame with an inner polycarbonate shell and the FFU on top. The small door on the front has hinges on the top that attach to magnets to hold in place. This hood was designed as a solid combined piece which increases the weight but is a single system.

Table 5. Pros and Cons of Vertical Laminar Flow Hood

Cons	Pros
Expensive materials	Single system
Thick polycarbonate	Low number of parts
Large component	Durable design
Heavy	Simple construction

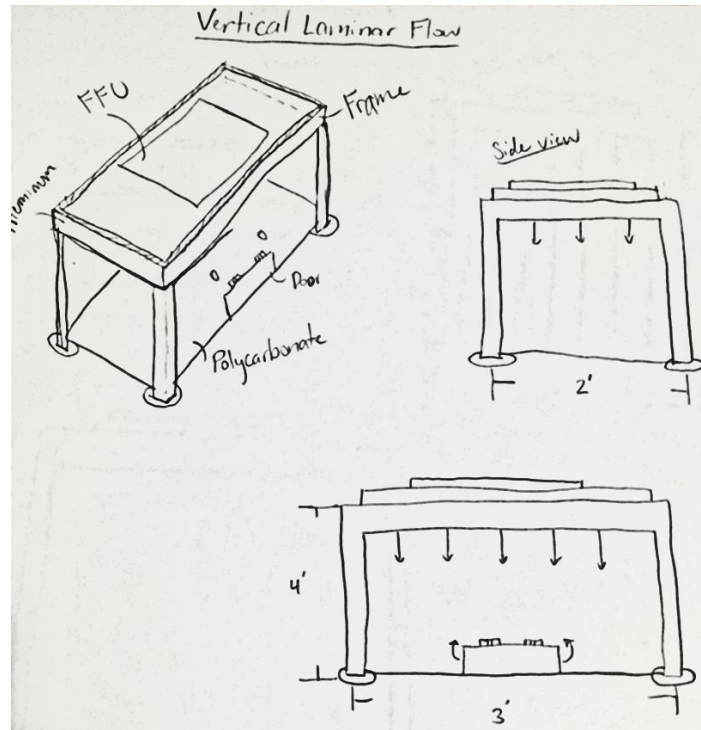

Figure 10: Vertical Laminar Flow Hood

4.1.4 Design #4: Horizontal Laminar Flow Hood with no Frame

The horizontal laminar flow hood design has the FFU unit on the back half of the system as seen in Figure 11. The front of the hood is open which will affect the positive pressure and with the FFU on the back will interfere with the equipment inside. With the FFU in the equipment will not be properly in the path of the clean filtered air. The polycarbonate walls may not have the ability to withstand the weight of the FFU.

Table 6. Design of Horizontal Laminar Flow Hood

Cons	Pros
Expensive material	Single system
Thick polycarbonate	Low number of parts
Large component	Durable design
Heavy	Simple construction

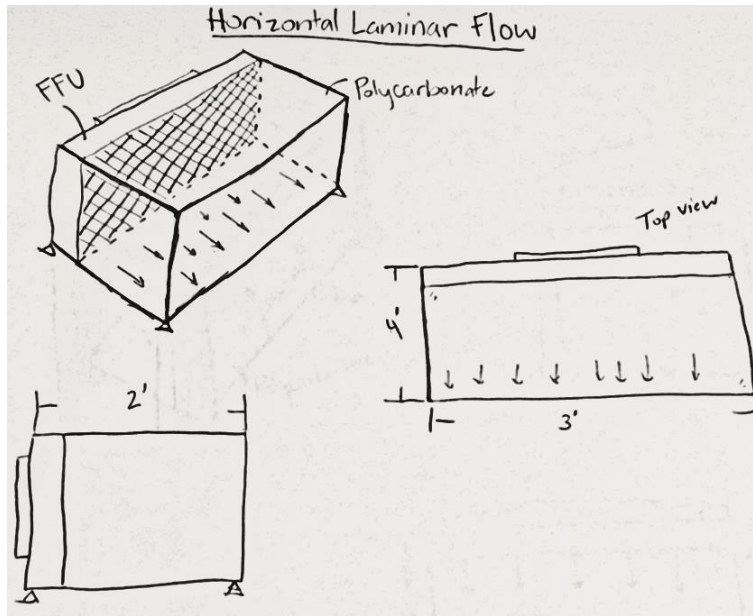

Figure 11. Design of Horizontal Laminar Flow Hood

4.2 Portable Clean Room Designs

Below are various concept designs for portable clean rooms.

4.2.1 Design #5: Clean Room with Detachable Frame

This design shows a clean room that has a frame which was to be adjustable based on the framing type being utilized. This concept tries to solve the issue of transportation through various locations. Using this type of framing will make it assemble and disassemble easier for the customer. The drawback was the use of the pricing on this type of material will raise the cost of the overall clean room.

Table 7. Pros and cons of Clean Room with detachable Frame

Cons	Pros
Cost of Frame	Lightweight
No wheels on room	Clear Panels
Assembly time	Durable Frame

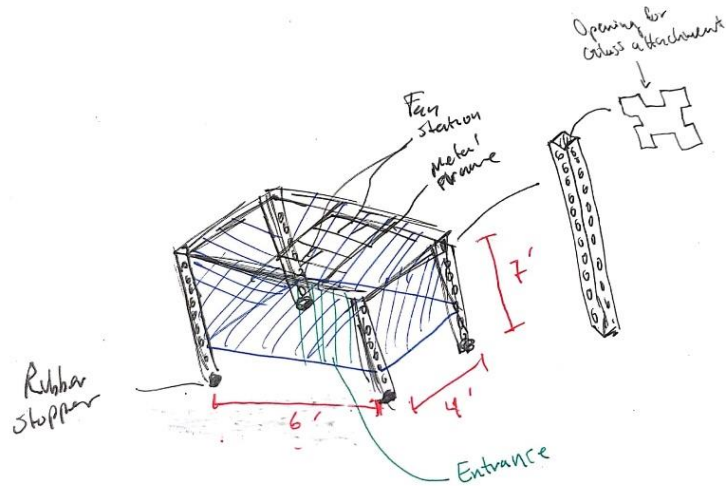

Figure 12. Design for Clean Room with detachable Frame

4.2.2 Design #6: Double Flap Clean room

The portable clean room in figure 11 shows the top view and front view. In the top view it can be seen there are two fans and the fans are spaced on the top for better air distribution. The fans are mounted in place and are supposed to be in the optimal position. In the front view the flaps on the entrance side are to have a double layer of plastic slats that are off set from each other to reduce the amount of air escaping, while the other three sides are solid vinyl sheeting, ensuring there is positive pressure in the structure. The bottom of the frame is to have castor wheels, so it can be easily moved, but also be locked in place.

Table 8. Pros and cons of Double Flap Clean room

Cons	Pros
Cost of Frame	Small pieces to carry
Fans don't slide/adjust	Clear panels
Assembly time	Durable structure
Fixed floor plan	Double layer of plastic sheeting at door
More material	Roll able/ moveable

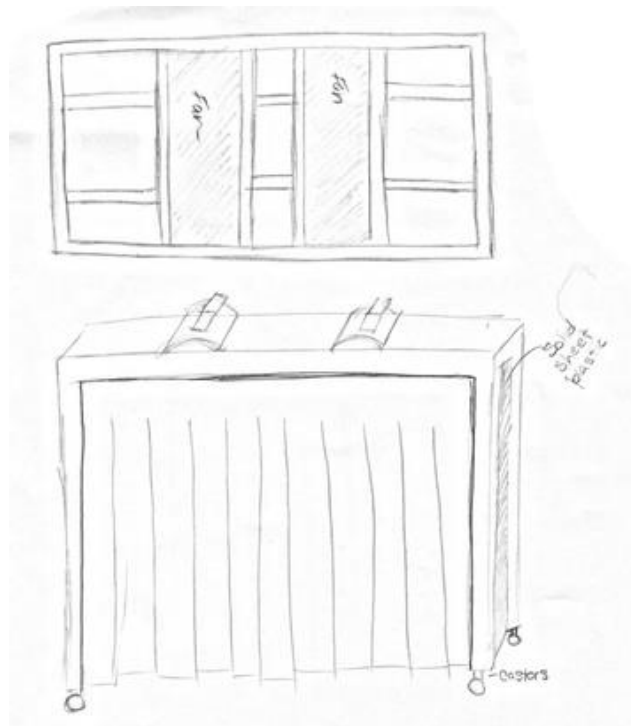

Figure 13. Design for Double Flap Clean room

4.2.3 Design #7: Portable Clean Room Single Flaps

The portable clean room as seen in Figure 14 below has two FFU units at the top, steel framing, clear plastic walls, with wheels as the feet, and single flap entrance unit. This system has steel framing with multiple pinned units this may create potential leaks of air but will be very heavy.

Cons	Pros
Heavy	Moveable
Fans don't slide/adjust	Clear panels
Multiple part	Durable structure
Potential small leaks	Easy to assemble

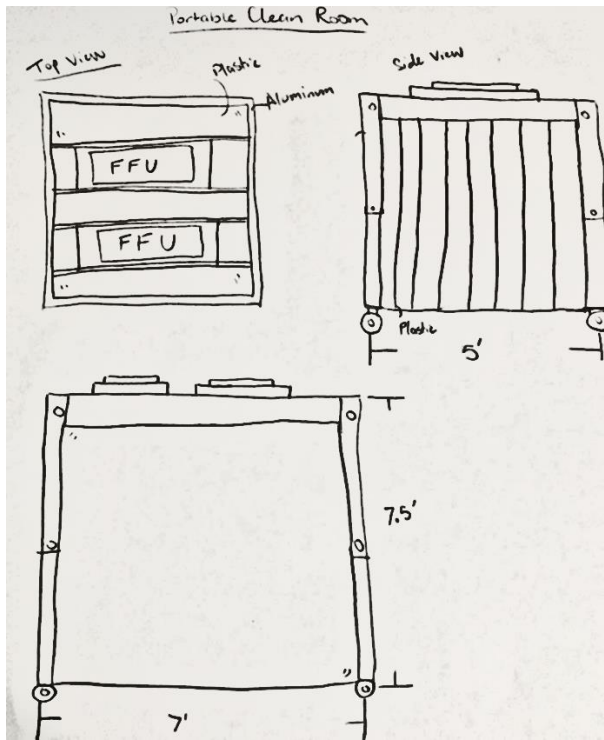

Figure 14. Design for Portable Clean Room Single Flaps

5 DESIGN SELECTED – First Semester

Various design concepts were considered but due to the constraints of the CRs and needing to meet FDA criteria, the overall design selected was an aluminum framed polycarbonate clean hood and an aluminum frame clear walled plastic clean room. The selection of two possible designs were made by comparing all the designs that were created with customer requirements. Using a Pugh chart, which used all of customer requirements and compared them to seven different designs described above and two in the Appendix. Each design was given a ranking according to the relevance to the CR's.

5.1 Rationale for Design Selection

The chosen hood design and room design meet the all the customer requirements while remaining under budget. The aluminum framing was decided upon because of how lightweight and durable the material was compared to steel, even though the cost is greater. The polycarbonate hood was specifically chosen by the client. The clear walled plastic was chosen for the visibility aspect, cost, and light weight. The rubber lining was chosen because of its elasticity and relative cost. The Pugh chart in table 9 is designed to show how each concept correlates with each CR. As seen in the Pugh chart, the hood design 2 and 4 ranked the highest because steel is cheaper than aluminum but is also heavy but are equivalent in all other aspects. The room designs all had a relative equal ranking but number 6 was the better option. The chosen designs for the hood and room can be seen in Figure 9 and Figure 13, respectively.

Table 9. Pugh Chart

Customer Requirements	Datum	1	2	3	4	5	6	7	8	9
Inexpensive	(+)	(-)	(+)	(-)	(+)	(-)	(-)	(+)	(-)	(+)
Portable	(+)	(+)	(+)(-)	(+)	(+)(-)	(+)	(+)	(+)(-)	(+)	(+)(-)
Positive Pressure	(+)	(+)	(+)	(+)	(+)	(+)	(+)	(+)	(+)	(+)
Visibility	(+)	(+)	(+)	(+)	(+)	(+)	(+)	(+)	(+)	(-)
Clean	(+)	(+)	(+)	(+)	(+)	(+)	(+)	(-)	(+)	(+)
Reliability	(+)	(+)	(+)	(+)	(+)	(+)	(+)	(+)	(+)	(+)
Durability	(+)	(+)	(+)	(+)	(+)	(+)(-)	(+)	(+)(-)	(+)(-)	(+)
Classification	(+)	(0)	(0)	(0)	(0)	(0)	(0)	(0)	(0)	(0)
Noise	(+)	(0)	(0)	(0)	(0)	(0)	(0)	(-)	(-)	(-)
Safety	(+)	(+)	(+)	(-)	(+)	(+)	(+)	(+)	(+)	(+)
Total (+)	10	7	8	6	8	7	7	7	6	7
Total (0)	0	2	2	2	2	2	2	1	1	1
Total (-)	0	1	1	2	1	2	1	4	3	3

1. Design 1 hood - Aluminum frame, polycarbonate hood, foam top lining

2. Design 2 hood - Steel frame, polycarbonate hood, rubber top lining

3. Design 3 hood - Aluminum frame, polycarbonate hood, rubber top lining

4. Design 4 hood - Steel frame, polycarbonate hood, foam top lining

5. Design 5 hood - Aluminum frame, acrylic hood, foam top lining

6. Design 1 room - Aluminum frame, 0.25" plastic wrap, duralock, lock pins

7. Design 2 room - Steel frame, 0.25" plastic wrap, velcro, latch locks

8. Design 3 room - Aluminum frame, 0.25" plastic wrap, velcro, latch locks

9. Design 4 room - Steel frame, 0.25" plastic wrap, duralock, lock pins

(+) - Positive Correlation

(0) - Neutral Correlation

(-) - Negative Correlation

5.2 Design Description

The final design will be produced next semester and is detailed within this section. Initially the designs were iterated and worked on multiple times to see which design worked best for the client. After multiple design concepts and approvals by the client the team was able to create two separate design concepts these two concepts will be detailed in section 6, and this section shows the final design and dimensions for the portable clean room.

5.2.1 Engineering Calculations

Using the proposed engineering requirements from Table 2 from section 2.2 there were a series of calculations used to determine if the clean room would operate within those parameters. Each team member took on a different task to work on the analysis required for the clean room. The following three main analysis on the clean room were the frame, pressure, and fan filter analysis. Each different analysis goes into detailing explaining the results for the calculations and can be found in Appendix D.

For this project, a fluid analysis was to be done on the portable hood and room to determine if a positive pressure would result with the chosen dimensions and fan filter units (FFU). The analysis was crucial because it was one of the client's requirements that both the hood and the room have positive pressure continuously while in use, ensuring a clean atmosphere within. Anevas Technology Inc. manufactures and researches minimal invasive microcatheter medical devices, used to treat aneurisms and other vascular defects in the brain. This project will benefit the client's research and development of their products by producing a clean low particle count work environment. There must be positive pressure in both units to be considered a clean atmosphere, meaning that the particle count is low and HEPA certified.

5.2.2 Model Drawings

The portable clean room chosen for the final design is shown in figure 15 above. The model shows the dimensions it will have and how the fans will sit once it is built. The shear pins will hold the collapsible legs in place giving the portable clean room a height of 84 inches in total. The wheels will be able to lock and unlock for easy mobility and the fans can be detached in order to reduce weight when transporting.

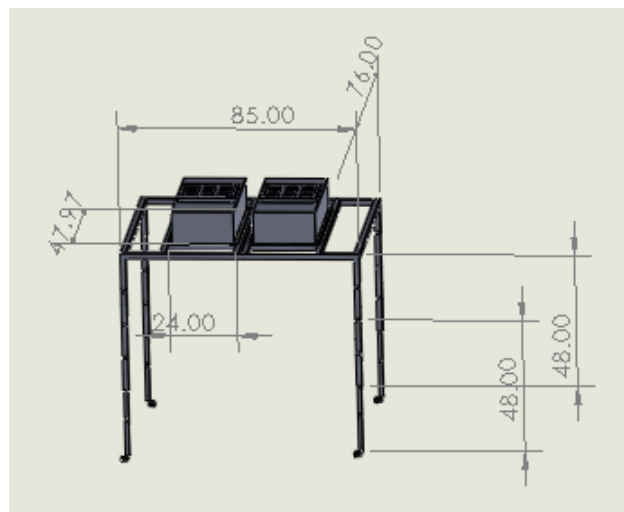

Figure 15. Portable Clean Room CAD Drawing

In figure 16 below is the 3D CAD model of the clean room for the final design. This design shows a clear image of the shear pins used to hold the legs of the clean room at different heights. It also shows the position of the fans located at the top being held together by their individual frame for maximum strength.

The wheels are also important to note since they will be used for ease of mobility when transporting from one location to the next.



Figure 16. Portable Room CAD Assembly

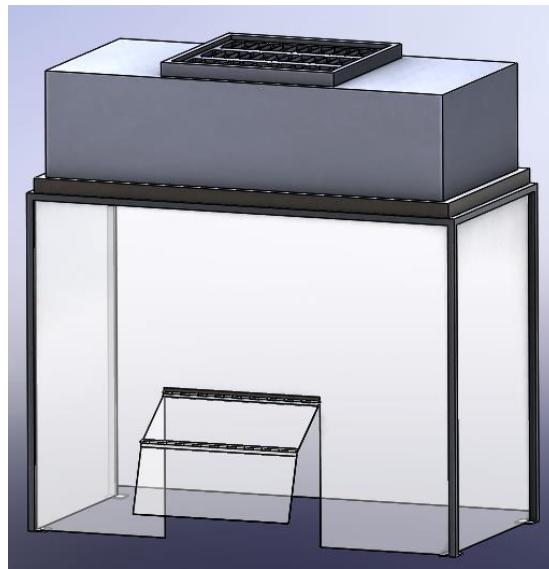

Figure 17. Portable Hood CAD Assembly

Figure 18 shows the exploded view of the portable hood, where balloon 1 is the polycarbonate door, 2 is the polycarbonate viewing window, 3 is the aluminum frame, 4 is the FFU, 5 is the pin to the hinges, and 6 are the wings for the hinges.

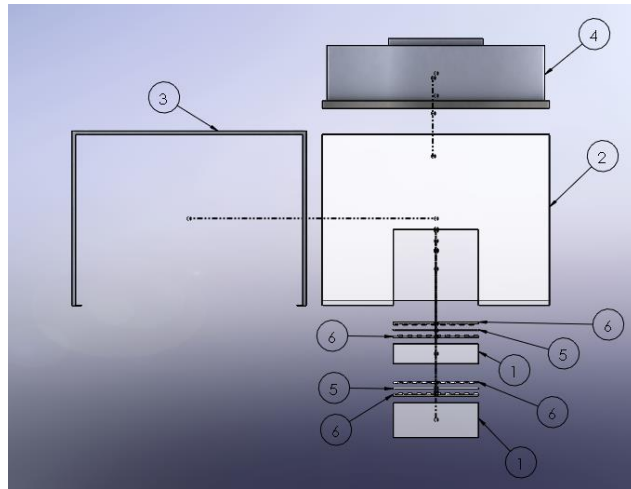

Figure 18. Portable Hood Exploded View

6 PROPOSED DESIGN – First Semester

The next process of design is to fabricate a prototype model of the hood and to order the chosen fan filter units from Terra Universal due to the length of time that it takes to ship [5]. Then start purchasing the list of material from the Bill of Materials (BOM), to build the final design. Fabrication for the project will be completed in building 98C, the machine shop on the NAU campus, it has all the needed equipment and tools. Once the final design is fabricated, measurements will be taken to verify that the customer’s dimensions are met, a pressure test will be done to verify that positive pressure is obtained and sustained. As stated in the testing procedure section above, the pressure will be measured using pressure transducers, a DAQ system, and the LabVIEW program.

6.1 Implementation of Design

To implement the design, the team will work together with several resources that are available. The frame will be made with the help of the machine shop, one of our teammates is recently certified for machining. This will prove to be helpful in the spring semester. To have more precise measurements for pressure distribution along the portable clean room, a group member has taken the task of learning CFD. Using the software ANSYS and creating a mesh out of the CAD file the team can create a more precise pressure distribution based on the geometry of the clean room. A Gantt chart (Appendix F) will be used to detail all the steps of the schedule for buying these materials. This will help with the manufacturing and the testing process, since it will detail all the steps to create and finalize both the hood and the room.

6.2 Bill of Materials

The bill of materials (Appendix E) contains the total quantity, cost and description of each material needed to create both the clean room and the portable hood. Starting with the FFU which will have to be ordered online through a source that specializes in fan filter units. The framing will come partially from the machine shop and the rest of the frame will be ordered through Home Depot. The steel shear pins will also be bought through Home Depot along with the wheels for the portable room. Welding for the project will be covered through the help of the machine shop. The other materials like epoxy and polycarbonate cutting tools will be bought through Home Depot.

6.3 Final Design Assembly View and Exploded View

Figure 16 provides a detail assembly image of the proposed final design project. Showing the different components for the clean room like the adjustable legs and the shear stress pins, as well as the fan filter units.



Figure 19. Portable Room CAD Exploded View

Figure 19 displays an exploded view of the portable clean room for the final design project. The lines show the way the different parts are attached based on the starting point and ending points of the lines.

Figure 17 from section 5.2.2 shows the portable hood design assembly for the final design project. The assembly shows the different components like the double hinge door, polycarbonate cover, as well as the fan filter unit.

Figure 18 from section 5.2.2 shows the exploded view for the portable hood for our final design project. The image showcases the different components by assigning a different to each part. Also implementing the line diagrams to show how the portable is assembled back together.

7 IMPLEMENTATION

Most of the implementation derived from the research and concept generation was done through the fall and beginning of spring semester. Given that the team was tasked two similar concepts with the difference being the size and material. When all the design research was done for both the hood and room the second stage was to research the best material for each unit, this allowed the team to remain within budget. After finding the best suited material the next step was to acquire the material needed to create the hood and the room. The purchase of the two fans needed for the room was done over the winter break, this was due to the uncertainty of shipping times for the fan filter units. Due to complications with the room's design and the expenses of the material, it was decided that the hood was to be manufactured first. It was decided that the frame was to be aluminum because it is lightweight and durable but also because it was donated by Northern Arizona University. The hood aspect of the design is to be polycarbonate because it can be cleaned easily and is visibly clear. The polycarbonate was purchased online. With the resources within the machine shop the team made exact cuts for the 1"x 1" hollow square aluminum tubing. The 4 ft x 4ft polycarbonate was cut with the assistants of Palomino glass company since they had the tools needed to cut the specific type of plastic. The team also presented specific drawings and approvals needed to create a work order to weld the aluminum frame of the hood. The team put together the polycarbonate panels to create the wall for the hood and install the door with the hinges to finalize the hood. Once the hood is done the room's frame will be the next task needed. The team has encountered design issues realizing the frame needed more supports to hold the FFU's weight. Once the room was redesigned and finalized the team researched a local company that can provide 1.5"x1.5"x1/8" steel hollow tubing needed for the room frame. Bare steel cannot be used within clean rooms due to the chemicals used to clean the environment and because it will deteriorate and rust quickly. Thus, the steel will be powder coated allowing it to be cleaned and will protect it. Mountain Shine, a local company, can apply the powder coating to the steel frame for the room. Testing procedures are currently being outlined and reviewed; a team member is currently working on an Arduino pressure sensor that can measure the pressure within the hood. This test will allow the team to analyze the pressure within the hood, verify the positive pressure within, and will help the users know when to change out the fan filters based on the drop of pressure that happens over time. Various steps were taken in completing this project. The biggest challenge was finding quality material while remaining under budget. During the process of the second technical analysis and prototyping the team discovered weaknesses within the proposed designs of the hood and room. These weaknesses required redesigning of the hood and room.

7.1 Manufacturing

The manufacturing for the hood and room were initially very similar. Both units are static structures that needed to be welded and secured. The hood presented its own unique manufacturing processes. Given the frame is aluminum and is outside the airflow of the FFU it does not need to be powder coated. Figure 20 below demonstrates the cutting process of the aluminum frame and in Figure 21 represent the fully cut aluminum frame for the hood. The primary concern with using aluminum as the frame is the welding. The welding of aluminum is difficult, can become expensive, and can make the material ductile. The polycarbonate has presented challenges in the manufacturing. The team used a ¼ inch thick sheet that is 4 ft x 4 ft which was too large for any of the tools within the machine shop. The process of cutting this type of material is with a CNC mill or a skill saw. The polycarbonate will be the inner casing that will direct and contain the airflow from the FFU. Epoxy will be used to join each polycarbonate panel. This will then set after a 24-hour curing process. The final manufacturing processes will include attaching a door with hinges to the front panel, applying magnets, and lining the top of the frame unit with rubber as a sealant. To attach the door to the front panel the team will drill four small holes at the top of the 18"x16" door and the front panel to attach a hinge. This door will also have a pair of magnets that will be epoxied, which will help keep the door open when the equipment is in use. A weather proof rubber sealer will be along the perimeter of the aluminum frame to seal the fan unit and the frame keeping potential air from escaping.



Figure 20: Cutting the Aluminum Frame



Figure 21: Fully. Cut Aluminum Frame for Hood

The room has been redesigned due to weaknesses found within the frame's structure. Due to the scope of the project changing from time constraints the team's current goal is to manufacture the frame unit of the room. Once the 1.5"x1.5"x1/8" square hollow steel tubing is acquired one of the team members will weld the frame together given that steel welding can be done in the machine shop if certified. Since the material for the room is steel a powder coat will be needed. The powder coating process is when an electrostatic spray is applied on a preheated part to attach the polymer resin. Since this type of manufacturing is very specific the team will use Mountain Shine Custom Finishing to do this part of the manufacturing process. Given the scope of the room has changed due to time this will be as far as the team can go with the manufacturing process.

Figure 22 represents one of the two identical Terra Universal Fan Filter Units purchased by Aneuvus Technology, Inc. These FFUs are 70 lbs. and will be placed on top of both units to induce the positive pressure laminar airflow.

Table 10 shows all the material that will be used for both the room and the hood. From Table 10 what is not highlighted has is what currently has been manufactured. The yellow highlight indicates that we have the material ready, but has not been manufactured it yet. Lastly, what is highlighted in orange is the material that has not been purchased and has not been manufactured at this point. All remaining material can be seen in Appendix 10.5 the BOM. A schedule, as seen in Appendix 10.6, (see appendix F) was created to outline all the needed deliverables to reach the final model. This will detail all the work that has been completed, and all the upcoming milestones needed to accomplish the final design for the room and the hood.



Figure 22.: Terra Universal Whisper Flow 2'x4' Fan Filter Unit

Table 10. Material and Resources needed for Manufacturing

Application	Part Name	Source	Use	Cost
Hood	Al-Frame	98C	Supports Fans	\$ -
	Polycarbonate	Interstate Platics	Seals Hood	\$ 529.52
	Cutting-Poly	Palomino Glass	Seals Hood	\$ 240.00
	Welding Al-Frame	98C	Outer Frame	\$ -
	Epoxy	Home Depot	Seals Polycarbonate	\$ 20.24
	Rubber Lining	Home Depot	Seals Roof	\$ 16.74
	Magnets	Home Depot	Holds door open	\$ 4.76
	Machine Screws	Home Depot	Holds door open	\$ 3.54
	Hinges	Home Depot	Holds door open	\$ 1.97
Room	Steel Frame	Mayorgas Welding	Supprts Room	\$ 326.70
	Welding Steel Fram	98C	Supports Room	\$ -
	Powder Coating	Mountain Shine	ISO Cerdtification	\$ 671.19
Total				\$1,814.66

Figure 22 above represents one of the two identical Terra Universal 2 ft x 4 ft Fan Filter Units purchased by Aneuvus Technology, Inc. These FFUs are 70 lbs. and will be placed on top of both units to induce the positive pressure laminar airflow. Table 10 above shows all the material that will be used in the manufacturing of both the room and the hood. From Table 10 what is not highlighted has currently been purchased and manufactured. The yellow highlight indicates that we have the material is purchased but has not been manufactured. Lastly, what is highlighted in orange is material that has not been purchased nor manufactured at this point. All remaining material can be seen in Appendix E the BOM. A schedule, as seen in Appendix F, was created to outline all the needed deliverables to reach the final model. This will detail all the work that has been done up to this point, and all the upcoming milestones needed to accomplish the final design for the room and the hood.

7.2 Design Changes

The first stage of prototyping and second stage of analytical analyses the team discovered weakness within the first proposed final designs. The portable clean hood and room had to be reevaluated and redesigned due to the discovered weaknesses within the structure of the frames and as well as new client design requests.

Through first stage of prototyping it was discovered that the hood needed more supports to uphold the weight of the FFU. As seen in Figure 23 below the two lower supports on the left and right side and two angled supports on the top back were added to the aluminum framing. These added supports allowed for greater stability and support to the unit. The client also at the time requested that the door be changed from a double hinged door to single hinged door. The design changes were successfully made and iterated into manufacturing.

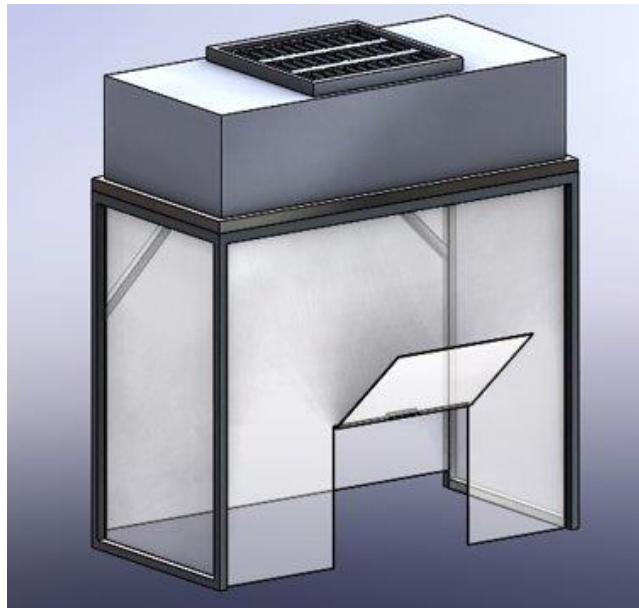

Figure 23: Redesign of Hood

From the second stage of analytical analyses it was discovered that the room's frame had various weak points. The room was redesigned with 1.5"x1.5"x1/8" square hollow steel tubing and with added supports to the bottom of the unit, as seen in Figure 24 below. Also due to the material changing to steel it is then required that the steel be powder coated to prolong the effects of erosion and protect the material from

cleaning chemicals. With the added supports the deflection of the 96" beam was calculated at 0.1459 and for the 72" beam the deflection was calculated at 0.0468. Additional changes were added due to the client's request that the legs be one solid piece rather than the legs telescoping. The room still has the capability of disassembling into smaller sections allowing portability as seen in Figure 25.



Figure 24: Redesigned Steel Frame for Room



Figure 25: Disassembled Steel Frame

Overall, the room has been the greatest challenge in trying to redesign the frame to be structurally safe and hold the weight of two FFUs while remaining under budget. Due to time constraints and continuously exceeding the budget, as seen in Appendix E and F, the client has requested that the team fully manufacture the hood, fully design the room, and manufacture the framing of the room. The team is confident that the hood will be successful in meeting the client's needs.

8 CONCLUSION

This report contained background, customer and engineering requirements, existing designs, designs created, design selected, design description, and the proposed design for the portable clean room and clean hood. The main design parameter is for the flow hood and clean room to have the ability to be disassembled and reassembled, have clean and sterilized air, maintain a positive pressure, and be portable. The team is currently manufacturing the final designs of the portable clean hood and room framing to present at the UGRADs and Symposium at the end of April, and the team will meet with the client to reveal the final fully manufacture products.

9 REFERENCES

- [1] "Clean Air Products," *Modular Softwall Clean Rooms*. [Online]. Available: <https://www.cleanairproducts.com/softwall-cleanrooms>. [Accessed: 27-Oct-2018].
- [2] "Fan Filter Unit; WhisperFlow, 2' x 4', HEPA, 120, Powder-Coated Steel," *Terra Universal*. [Online]. Available: <https://www.terrauniversal.com/product/6601-24-H>. [Accessed: 29-Nov-2018].
- [3] "FFU - Fan Filter Unit," *Price Industries*. [Online]. Available: <https://www.priceindustries.com/criticalenvironments/products/fan-filter-unit>. [Accessed: 30-Nov-2018].
- [4] "Horizontal vs Vertical Laminar Flow Hoods," *Terra Universal Blog*, 20-Feb-2018. [Online]. Available: <https://www.terrauniversal.com/blog/all-terra-blogs/horizontal-vs-vertical-laminar-flow-hoods/>. [Accessed: 27-Oct-2018].
- [5] "Clean Air Products," *Motorized Ceiling Fan Filter Unit CAP 118*. [Online]. Available: <https://www.cleanairproducts.com/motorizedceilingfanfilterunitcap118>. [Accessed: 29-Nov-2018].
- [6] "Softwall Cleanrooms[SWCR]," *Modular Softwall Cleanrooms | Vertical Flow | NCI*. [Online]. Available: <https://www.innotechprod.com/softwall-cleanrooms.html>. [Accessed: 27-Oct-2018].
- [7] "Vertical Laminar Flow Wash Out Base Clean Benches WO CAP412," *Vertical Laminar Clean Benches | Flow Wash Out Base Clean Benches | WO CAP412 Cl*. [Online]. Available: <https://www.cleanairproducts.com/verticallaminarflowwashoutbasecleanbencheswocap412>. [Accessed: 27-Oct-2018].
- [8] "HEPA and ULPA Particle Filters — Ductless Exhaust Hood Accessories from Terra Universal", *Terrauniversal.com*, 2018. [Online]. Available: <https://www.terrauniversal.com/laminar-flow-hoods/particlefilters.php>. [Accessed: 28- Oct- 2018].
- [9] "FS209E and ISO Cleanroom Standards.", *Terrauniversal.com*, 2018. [Online]. Available: <https://www.terrauniversal.com/cleanrooms/iso-classification-cleanroom-standards.php>. [Accessed: 28-Oct2018].
- [10] "Using HEPA filters to bring about a clean room environment - The Engineers Journal," *Engineers Journal*, 20Apr-2016. [Online]. Available: <http://www.engineersjournal.ie/2015/05/20/clean-room-environments/>. [Accessed: 28-Oct-2018].
- [11] P. Robert E. Monaghan, "The Essentials of Clean Room Maintenance," 01 June 2005. [Online]. Available: <https://www.contractingbusiness.com/archive/essentials-clean-room-maintenance>. [Accessed 28 October 2018].
- [12] "WhisperFlow Laminar Fan/Filter Units (FFUs).", *Terrauniversal.com*, 2018. [Online]. Available: <https://www.terrauniversal.com/cleanrooms/clean-rooms-fan-filter-units.php>. [Accessed: 28-Oct-2018].
- [13] "Clean Air Products," *Modular Hardwall Clean Rooms*. [Online]. Available: <https://www.cleanairproducts.com/hardwallcleanrooms/standardhardwallcleanrooms>. [Accessed: 30-Nov-2018].

10 APPENDICES

10.1 Appendix A: House of Quality

Table 2. House of Quality

System QFD		Project: Aneuvus Technologies Inc. Clean Room and Hood													
		Date: September 20, 2018													
		Input areas are in tan													
Dimensions -Area	m ²														
Pressure	Pa														
Weight	kg	(++)													
Cost	\$\$	(++)	(++)												
Assembly Time	min		(++)	(+)											
Power	W		(+-)	(+/-)											
Number of Particles	m ³		(++)	(+/-)		(++)									
Velocity	m/s		(++)			(++)	(++)								
Hood Material	n/a	(++)	(++)	(++)	(++)	(+)									
Room Material	n/a	(++)	(++)	(++)	(++)	(+)									
Stress	Pa		(++)						(+)	(++)	(++)				
Frequency	dBa			(+)			(+/-)								
Technical Requirements															
Customer Needs	Customer Weights	Dimensions -Area	Pressure	Weight	Cost	Assembly Time	Power	Number of Particles	Velocity	Hood Material	Room Material	Stress	Sound		
Inexpensive	5	3		3	9	3	1	1		9	9				1
Portable	3	9	1	3	3	9	3			1	1				
Positive Pressure	5		9		1		3	9	9			1			3
Visibility	2					3				9	9				
Clean	4	1	9		3		3	9	3	9	9				9
Reliability	3	3		1		1						9			
Durability	3	3				1				3	3	9			
Classification	5		9		9		3	9	1						9
Noise	4														9
Technical Requirement Units		m ²	Pa	kg	\$\$	min	W	m ³	m/s	n/a	n/a	Pa	dBa		
Technical Requirement Raw Score		64	129	27	116	54	56	131	62	111	111	59	12		
Relative Weight %		6.9565	14.02	2.935	12.61	5.87	6.087	14.23913	6.73913043	12.07	12.07	6.413043	1.382		
Target ER Values Hood		0.7432		45.36	1000	2	576	102,000	0.58	-	-		54		
Target ER Values Room		2.23		54.43	1000	15	576	102,000	0.58	-	-		54		
Rank Order		6	2	11	5	9	10	1	7	3	4	8	12		

10.2 Appendix B: Portable Hood with Adjustable Frame

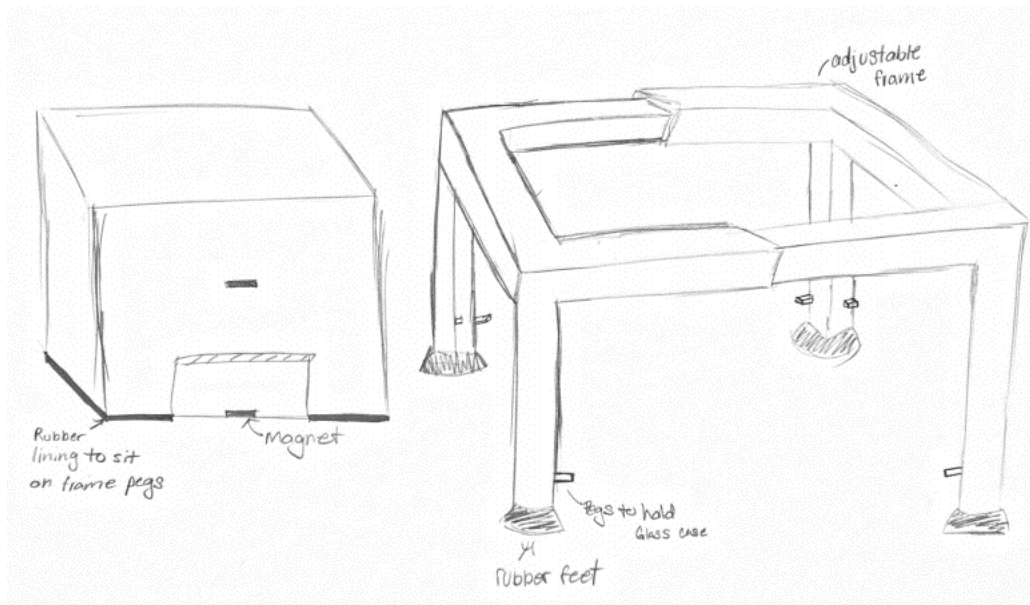

Figure 26. Portable Hood with Adjustable Frame

10.3 Appendix C: Portable Hood with Tabbed Framing

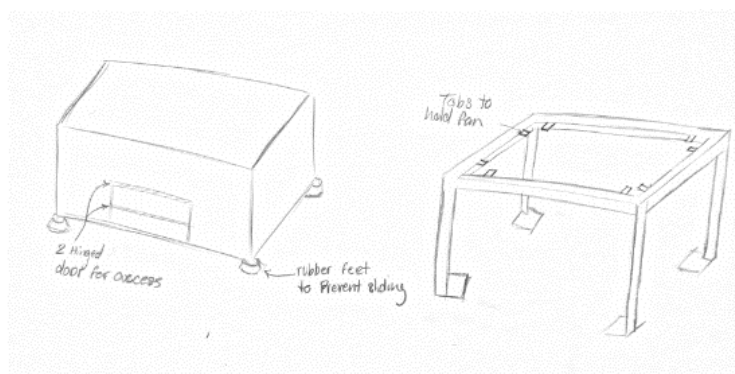

Figure 27. Portable Hood with Tabbed Framing

10.4 Appendix D: Technical Analysis

Frame Analysis

These assumptions were taken based on the customer requirements of the size of the clean room and portable hood. This will also account for the material used, based on several meetings with our client the preferred material for frame is aluminum. This is due to the fact of the overall strength durability and lightweight nature of aluminum. The other assumption was the aluminum framing for the hood is 1in x 1in cross sectional area and hollow, and for the portable room it is 2in x 2in cross sectional area hollow. Both frames will have a load of 35 pound given that the fan is 70 pounds. This is since the fan will be held by two parallel frames which will distribute the weigh evenly therefore just having a load of 35 pound in one side of the frame.

10.4.1.1.1 Details of Physical Model

Using an outer skeleton as a frame which reduces the strain on the polycarbonate walls of the room. The frame is used to hold the FFU and is sealed with the help of an adhesive which can be removed easily. The frame is made from aluminum which reduces the weight of the overall clean room. This helps with the ease of transportation which is a requirement by the customer. The polycarbonate walls have an entrance point that is 6inx12in which is required for working within the station. The bad thing about this device is the opening which is a hinge style opening which may reduce the visibility of the user when working. Another con may be the outer frame can also decrease the visibility when looking through the sides of portable hood

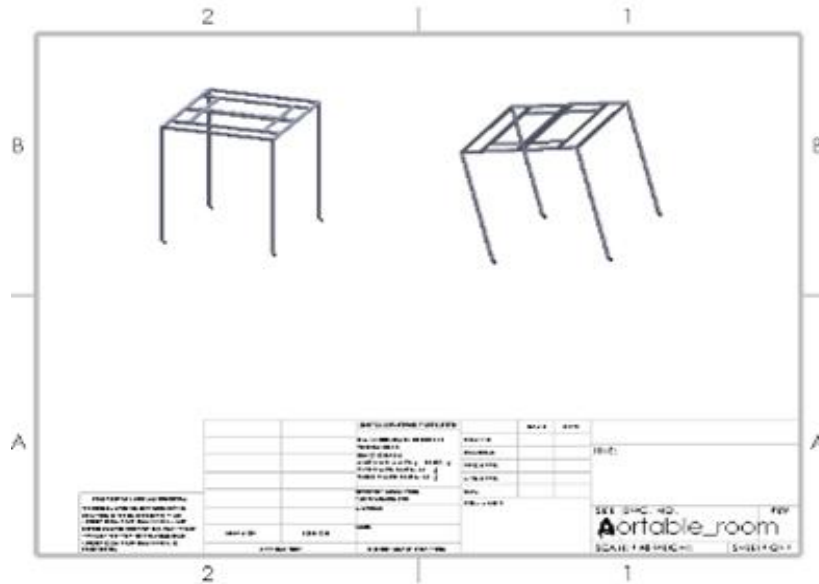

The portable clean room in figure shows the top view and front view. In the top view it can be seen there are two fans and the fans are spaced on the top for better air distribution. The fans are mounted in place and are supposed to be in the optimal position. In the front view the flaps on the entrance side are to have a double layer of plastic slats that are off set from each other to reduce the amount of air escaping, while the other three sides are solid vinyl sheeting, ensuring there is positive pressure in the structure. The bottom of the frame is to have castor wheels, so it can be easily moved, but also be locked in place.

10.4.1.1.2 Equations

These equations were used to understand the mechanism going on within the frame. Using the stated assumptions, the frame was under a distributed load across the frame in the y-axis direction. Illustrating the shear and bending moment equations and the reaction forces within the system. The calculations were used to understand the maximum bending a shear moment acting on the frame for both the portable hood and room.

$$\sum F_{xyz} = 0 \tag{1}$$

This equation shows the sum of the forces acting on x, y, and z direction. This is a very important factor since the distributed load on the frame will have reactions forces that are on the frame.

$$\tau = \pm \frac{v}{A} \tag{2}$$

$$\sum v = 0 \tag{3}$$

This equation is the sum of the shear moments along with how the shear moment equation is derived using tow. This will help understand the shear force being applied due to the initial distributed load of the fan.

$$\sum M = 0 \tag{4}$$

$$dM = \delta v dx \tag{5}$$

These equations were used to understand the bending moments happening within the frame. This is important since bending moments can be accumulated based on the load being applied.

$$S_{max} = \frac{p}{A_{net}} \tag{6}$$

This equation is used to get the maximum tensile stress for acting on the frame based on the distributed load being added.

10.4.1.1.3 2.4 Software Used

GS-USA is a software that is used to analyses different types of frames. This software can be used by setting specific parameters specific to what you need. I set the material property to aluminum and a hollow cross-sectional area of 1x1 in and 2x2 in for the hood and the portable room. The next step was to set nodes which are the x and y coordinates for the hood and the portable room. This will allow you to have a 2d look at where the coordinates of the frame will be. The next step is to assign elements to each of the nodes, this is the actual straight line or the frame of the design. For both frame analysis conducted the frame was the same given that they are going to be sitting with the same dimensions. The only difference between the room and hood is the cross-sectional area which was mentioned earlier. Given these inputs the software then can calculate the min and max bending moments as well as shear diagrams. Another interesting data given for this analysis is the maximum tensile strengths.

This analysis shows the how the distributed load acts on the frame. Based on the assumptions made initially a technical analysis was able to be done. Using the software and following the governing equations structural analysis was done. The maximum bending moment and shear diagram showed that both the room and hood frame would be able to withstand the distributed being applied based on the weight of the fan. The other important aspect was the maximum tensile stress that occurs within the frame this too also showed to be able to have met the requirements for the framing being used for this demand. Ultimately the framing can be reasonably said to withstand the weight of the fans which will hold safely based on the technical analysis illustrated. The future work will be to apply this analysis if there are any future changes to the design which can be easily done following this technical analysis.

10.4.1.2 Pressure Analysis

For this project, it was decided that a fluid analysis is to be done on the portable hood and room to determine if a positive pressure will result with the chosen dimensions and fan filter units (FFU). The analysis is crucial because it is one of the client’s requirements that both the hood and the room have positive pressure continuously while in use. The company manufactures and analyzes minimal invasive microcatheter medical devices, used to treat aneurisms and other vascular defects in the brain. This project will benefit the client’s research and development of their products by producing a clean low particle count work environment. There must be positive pressure in both units to be considered a clean atmosphere, meaning that the particle count is low and HEPA certified.

10.4.1.2.1 Assumptions, Equations, and Variables

For this project, it was decided that a fluid analysis is to be done on the portable hood and room to

determine if a positive pressure will result with the chosen dimensions and fan filter units (FFU). The analysis is crucial because it is one of the client's requirements that both the hood and the room have positive pressure continuously while in use. The company manufactures and analyzes minimal invasive microcatheter medical devices, used to treat aneurisms and other vascular defects in the brain. This project will benefit the client's research and development of their products by producing a clean low particle count work environment. There has to be positive pressure in both units to be considered a clean atmosphere, meaning that the particle count is low and HEPA certified.

10.4.1.2.2 Assumptions

This section of the report contains assumptions, equations, and variables used in analyzing the fluid flow and the pressure within the room and the hood.

Assumptions

1. Incompressible flow, $\rho = \text{constant}$
2. Steady state, $\frac{\partial}{\partial t} = 0$
3. Mass flow rate in equals mass flow rate out, $\dot{m}_{in} = \dot{m}_{out}$
4. The FFU is treated as a pump, as one whole unit
5. The relative roughness is smooth
6. The polycarbonate case is to be treated as a duct

Equations

Equation 1: Mass flow rate

$$\dot{m} = \dot{V} * \rho$$

Equation 1 calculates the mass flow rate by multiplying the volumetric flow rate given which then allows the ability to obtain the velocity at various points.

Equation 2: Velocity

$$V = \frac{\dot{m}}{\rho * A}$$

The equation above can calculate the velocity by taking the calculated flow rate and dividing it by the density of air and the area with which the velocity is flowing through.

Equation 3: Hydraulic diameter

$$D_h = \frac{4Lw}{2(L + w)}$$

The equation above calculates the hydraulic diameter by using the 2 times the area divided by the perimeter of the unit which then will be applied to equation 4 below.

Equation 4: Head supply of pump

$$h_{SP} = \frac{P}{\dot{m}}$$

This equation calculates the head supply of the unit, by taking the power of the FFU and dividing it by the mass flow rate.

Equation 5: Reynold's number

$$Re = \frac{\rho VL}{\mu}$$

The Reynolds number is a dimensionless number, the calculation determines the type of flow that the FFU produces through the hood and room. If less than 2300 the flow is laminar and if the value is greater than 4000 the flow is turbulent.

Equation 6: Head loss major of unit

$$h_{LM} = f * \left(\frac{L}{D_h}\right) \left(\frac{V^2}{2}\right)$$

Equation 6 above calculates the major head loss that occurs through the hood and room.

Equation 7: Pipe flow energy equation

$$h_{LM} - h_{SP} = \left(\frac{P_1}{\rho} + \frac{V_1^2}{2} + gz_1\right) - \left(\frac{P_2}{\rho} + \frac{V_2^2}{2} + gz_2\right)$$

$$h_{LM2} + h_{LM3} = \left(\frac{P_2}{\rho} + \frac{V_2^2}{2} + gz_2\right) - \left(\frac{P_3}{\rho} + \frac{V_3^2}{2} + gz_3\right)$$

This equation is used to obtain the value of pressure 2 located 6" below the FFU and pressure 3 located at the bottom of the entire unit. This equation will show whether or not that either unit maintains a positive pressure throughout.

Nomenclature

P_{low} – Power at low setting [W] $\left[\frac{kg * m^2}{s^3}\right]$

h_{LM2} – Head loss Major of pump unit for 6" below FFU $\left[\frac{m^2}{s^2}\right]$

h_{LM3} – Head loss Major of pump for bottom of unit $\left[\frac{m^2}{s^2}\right]$

h_{SP} – Head supply of pump unit $\left[\frac{m^2}{s^2}\right]$

D_{h2} – Hydraulic Diameter for 6" below FFU [m]

D_{h3} – Hydraulic Diameter for bottom of unit [m]

\dot{V}_{low} – Volumetric flow rate at low setting $\left[\frac{m^3}{s}\right]$

\dot{m}_{low} – Mass flow rate at low setting $\left[\frac{kg}{s}\right]$

h_{fan} – Height of fan unit [m]

h_{hood} – Height of hood [m]

h_{door} – Height of door [m]

L – Length [m]

w – width [m]

A – Area of unit [m²]

A_{pf} – Area of pre – filter [m²]

V_1 – Velocity at top of hood [$\frac{m}{s}$]

V_2 – Velocity located 6" below FFU [$\frac{m}{s}$]

V_3 – Velocity at bottom of unit [$\frac{m}{s}$]

z_1 – Hight at point 1(top of fan) [m]

z_2 – Hight at point 2(6" below fan) [m]

z_3 – Hight at point 3(bottom of unit) [m]

g – Earth's gravity [$\frac{m}{s^2}$]

p_1 – Atmospheric pressure in Flagstaff [$\frac{kg}{ms^2}$]

p_2 – Pressure 6" below FFU [$\frac{kg}{ms^2}$]

p_3 – Pressure at bottom of unit [$\frac{kg}{ms^2}$]

Re – Reynolds number

f_2 – Friction factor for 6" below FFU

f_3 – Friction factor for bottom of unit

ρ – Density of air in Flagstaff [$\frac{kg}{m^3}$]

μ – viscosity of air [$\frac{kg}{ms}$]

10.4.1.2.3 Schematic of the Hood and Room

This section of the report a schematic of the clean hood and the clean room.

10.4.1.2.3.1 Clean Hood

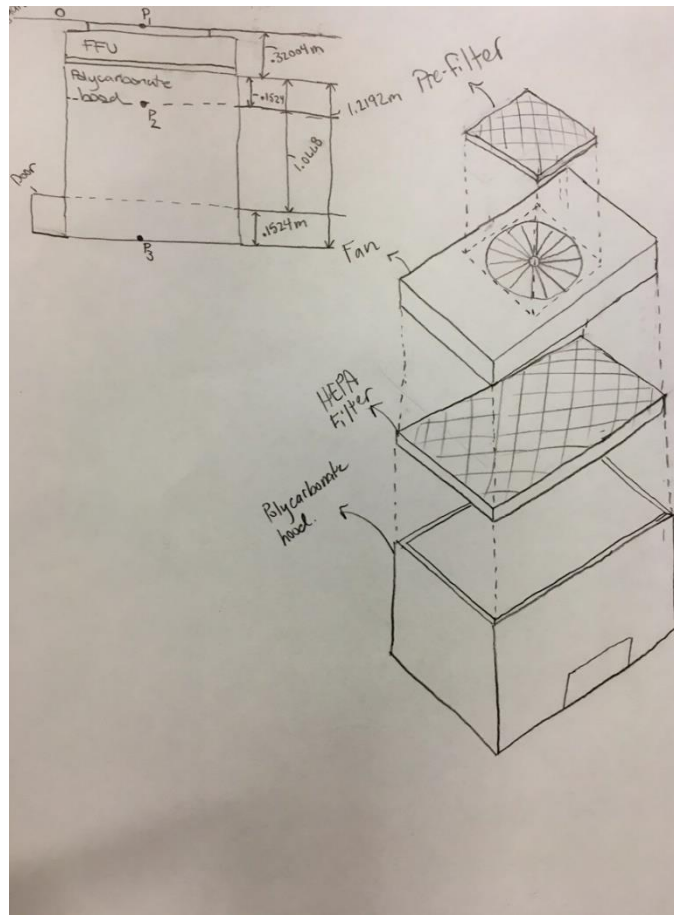

Figure 28: 2'x4' Clean Hood

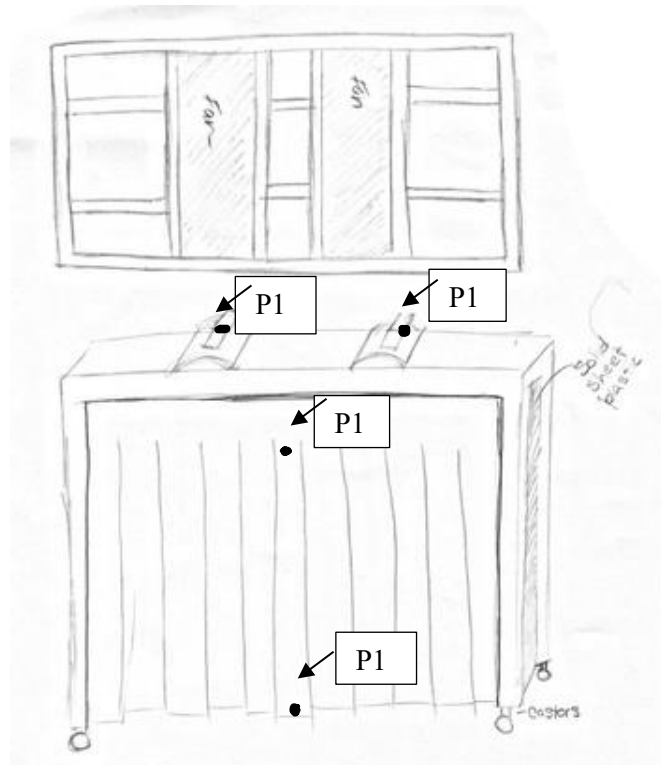

Figure 29: 6'x8'x8' Portable Room

10.4.1.2.4 Equation Flow Chart

This section of the report contains the details of how the equations in the section above are calculated and applied in the analysis.

10.4.1.2.5 Calculations

10.4.1.2.5.1 2'x4' Clean Hood

In this section is the calculations for the 2'x4' clean hood at the low speed setting. Listed below are the known variables.

$$P = 393 W \left[\frac{kgm^2}{s^3} \right]$$

$$\dot{V} = 0.3087 \frac{m^3}{s}$$

$$h_{hood} = 1.219 m$$

$$h_{fan} = 0.332 m$$

$$h_{door} = 0.1524 m$$

$$h_{6" \text{ below fan}} = 0.1524 m$$

$$L_2 = 0.1524 m$$

$$L_3 = 1.067 m$$

$$w = 0.6096 m$$

$$A_{pre-filter} = 0.2581 m^2$$

$$z_1 = 0 m$$

$$z_2 = 0.15837 m$$

$$z_3 = 1.067 \text{ m}$$

$$\rho_{\text{flagstaff}} = 1.20 \frac{\text{kg}}{\text{m}^3}$$

$$p_{\text{flagstaff}} = 797156 \frac{\text{kg}}{\text{m} \cdot \text{s}^2}$$

$$V_2 = V_3 = 0.4724 \frac{\text{m}}{\text{s}}$$

$$\mu = 1.8 \times 10^{-6} \frac{\text{kg}}{\text{m} \cdot \text{s}}$$

Listed below is the calculation process taken to prove that there is a positive pressure at the bottom of the unit.

$$\dot{m} = \dot{V} \rho = 0.3087 * 1.20 = 0.37044 \frac{\text{kg}}{\text{s}}$$

$$V_1 = \frac{\dot{m}}{\rho A_{pf}} = \frac{0.37044}{1.20 * 0.2581} = 1.1961 \frac{\text{m}}{\text{s}}$$

$$h_{SP} = \frac{P}{\dot{m}} = \frac{393}{0.37044} = 1060.9 \frac{\text{m}^2}{\text{s}^2}$$

$$Re = \frac{\rho V L}{\mu} = \frac{1.20 * 0.4724 * 0.15837}{1.8 \times 10^{-6}} = 49876 > 2300 - \text{Turbulent Flow}$$

Reynold's number and assumption 5 are applied to the Moody's Diagram to estimate the friction factor.
[2]

$$f_2 \approx 0.037$$

$$D_{h2} = \frac{2L_2w}{L + w} = \frac{2 * 0.15837 * 0.6096}{0.15837 + 0.6096} = 0.25142 \text{ m}$$

$$h_{IM2} = f_2 * \left(\frac{L}{D_{h2}}\right) \left(\frac{V_2^2}{2}\right) = 0.037 * \left(\frac{0.15837}{0.25142}\right) \left(\frac{0.4724^2}{2}\right) = 0.002601 \frac{\text{m}^2}{\text{s}^2}$$

$$h_{IM} - h_{SP} = \left(\frac{P_1}{\rho} + \frac{V_1^2}{2} + gz_1\right) - \left(\frac{P_2}{\rho} + \frac{V_2^2}{2} + gz_2\right)$$

$$\rightarrow 0.002601 - 1060.9 = \left(\frac{79715.6}{1.20} + \frac{1.196^2}{2} + 0\right) - \left(\frac{P_2}{1.20} + \frac{0.4724^2}{2} + (9.81)(0.15837)\right)$$

$$\rightarrow -1060.9 = (66429.7 + 0.71521) - \left(\frac{P_2}{1.20} + 0.11158 - 1.5536\right)$$

$$\rightarrow -1060.9 = 66430.4 - \frac{P_2}{1.20} + 1.44202$$

$$\rightarrow -1060.9 = 66429 - \frac{P_2}{1.20}$$

$$\rightarrow -67489.9 = -\frac{P_2}{1.20}$$

$$\rightarrow P_2 = 80988 \text{ Pa}$$

With the pressure known at point 2, use same equations to find the pressure at point 3 which is the bottom of the unit.

$$Re = \frac{\rho VL}{\mu} = \frac{1.20 * 0.4724 * 1.067}{1.8 \times 10^{-6}} = 336034 > 2300 - \text{Turbulent Flow}$$

Reynold's number and assumption 5 are applied to the Moody's Diagram to estimate the friction factor. [2]

$$f_3 \approx 0.0235$$

$$D_{h3} = \frac{2L_3w}{L+w} = \frac{2 * 1.067 * 0.6096}{1.067 + 0.6096} = 0.77591 \text{ m}$$

$$h_{LM3} = f_3 * \left(\frac{L}{D_{h3}}\right) \left(\frac{V_2^2}{2}\right) = 0.0235 * \left(\frac{1.067}{0.77591}\right) \left(\frac{0.4724^2}{2}\right) = 0.005431 \frac{m^2}{s^2}$$

$$h_{LM2} + h_{LM3} = \left(\frac{P_2}{\rho} + \frac{V_2^2}{2} + gz_2\right) - \left(\frac{P_3}{\rho} + \frac{V_3^2}{2} + gz_3\right)$$

$$\rightarrow 0.002601 + 0.005431$$

$$= \left(\frac{80988}{1.20} + \frac{0.4724^2}{2} + (9.81)(0.15837)\right) - \left(\frac{P_3}{1.20} + \frac{0.4724^2}{2} - (9.81)(1.076)\right)$$

$$\rightarrow 0.008031 = (67490 + 0.11158 + 1.5536) - \left(\frac{P_3}{1.20} + 0.11158 - 10.556\right)$$

$$\rightarrow 0.008031 = 67488.6 - \frac{P_3}{1.20} + 10.444$$

$$\rightarrow 0.008031 = 67499 - \frac{P_3}{1.20}$$

$$\rightarrow -67499 = -\frac{P_3}{1.20}$$

$$P_3 = 80999 \text{ Pa}$$

10.4.1.2.6 6'x8'x8' Clean Room

In this section is the calculations for the 6'x8'x8' clean room with 2 FFUs at the low speed setting. Listed below are the known variables for one 2'x4' FFU.

$$\begin{aligned}
P &= 393 \text{ W} \left[\frac{\text{kgm}^2}{\text{s}^3} \right] \\
\dot{V} &= 0.3087 \frac{\text{m}^3}{\text{s}} \\
h_{\text{room}} &= 2.438 \text{ m} \\
h_{\text{fan}} &= 0.332 \text{ m} \\
h_{\text{spacing}} &= 0.305 \text{ m} \\
h_{6'' \text{ below fan}} &= 0.1524 \text{ m} \\
L_2 &= 0.1524 \text{ m} \\
L_3 &= 1.9801 \text{ m} \\
w &= 1.8288 \text{ m} \\
A_{\text{pre-filter}} &= 0.2581 \text{ m}^2 \\
z_1 &= 0 \text{ m} \\
z_2 &= 0.15837 \text{ m} \\
z_3 &= 1.9801 \text{ m} \\
\rho_{\text{flagstaff}} &= 1.20 \frac{\text{kg}}{\text{m}^3} \\
p_{\text{flagstaff}} &= 797156 \frac{\text{kg}}{\text{ms}^2} \\
V_2 = V_3 &= 0.4724 \frac{\text{m}}{\text{s}} \\
\mu &= 1.8 \times 10^{-6} \frac{\text{kg}}{\text{ms}}
\end{aligned}$$

Listed below is the calculation process taken to prove that there is a positive pressure at the bottom of the unit.

$$\dot{m} = 2\dot{V}\rho = 2 * 0.3087 * 1.20 = 0.74088 \frac{\text{kg}}{\text{s}} \rightarrow 2 \text{ FFUs}$$

$$V_1 = \frac{\dot{m}}{\rho A_{pf}} = \frac{0.74088}{1.20 * 0.2581} = 2.3921 \frac{\text{m}}{\text{s}} \rightarrow 2 \text{ FFUs}$$

$$h_{SP} = \frac{2P}{\dot{m}} = \frac{2 * 393}{0.74088} = 1060.9 \frac{\text{m}^2}{\text{s}^2}$$

$$Re = \frac{\rho VL}{\mu} = \frac{1.20 * 0.4724 * 0.15837}{1.8 \times 10^{-6}} = 49876 > 2300 - \text{Turbulent Flow}$$

Reynold's number and assumption 5 are applied to the Moody's Diagram to estimate the friction factor. [2]

$$f_2 \approx 0.037$$

$$D_{h2} = \frac{2L_2w}{L + w} = \frac{2 * 0.15837 * 1.8288}{0.15837 + 1.8288} = 0.291497 \text{ m}$$

$$h_{LM2} = f_2 * \left(\frac{L}{D_{h2}} \right) \left(\frac{V_2^2}{2} \right) = 0.037 * \left(\frac{0.15837}{0.291497} \right) \left(\frac{0.4724^2}{2} \right) = 0.002243 \frac{\text{m}^2}{\text{s}^2}$$

$$\begin{aligned}
h_{1M} - h_{SP} &= \left(\frac{P_1}{\rho} + \frac{V_1^2}{2} + gz_1 \right) - \left(\frac{P_2}{\rho} + \frac{V_2^2}{2} + gz_2 \right) \\
\rightarrow 0.002243 - 1060.9 &= \left(\frac{79715.6}{1.20} + \frac{2.3921^2}{2} + 0 \right) - \left(\frac{P_2}{1.20} + \frac{0.4724^2}{2} + (9.81)(0.15837) \right) \\
\rightarrow -1060.9 &= (66429.7 + 2.8611) - \left(\frac{P_2}{1.20} + 0.11158 - 1.5536 \right) \\
\rightarrow -1060.9 &= 66432.6 - \frac{P_2}{1.20} + 1.44202 \\
\rightarrow -1060.9 &= 66434 - \frac{P_2}{0.813} \\
\rightarrow -67494.9 &= -\frac{P_2}{1.20} \\
\rightarrow P_2 &= 80994 \text{ Pa}
\end{aligned}$$

With the pressure known at point 2, use same equations to find the pressure at point 3 which is the bottom of the unit.

$$Re = \frac{\rho VL}{\mu} = \frac{1.20 * 0.4724 * 1.9801}{1.8 \times 10^{-6}} = 623599 > 2300 - \text{Turbulent Flow}$$

Reynold's number and assumption 5 are applied to the Moody's Diagram to estimate the friction factor. [2]

$$f_3 \approx 0.0198$$

$$D_{h3} = \frac{2L_3w}{L+w} = \frac{2 * 1.9801 * 1.8288}{1.9801 + 1.8288} = 1.9014 \text{ m}$$

$$h_{1M3} = f_3 * \left(\frac{L}{D_{h3}} \right) \left(\frac{V_2^2}{2} \right) = 0.0198 * \left(\frac{1.9801}{1.9014} \right) \left(\frac{0.4724^2}{2} \right) = 0.002301 \frac{m^2}{s^2}$$

$$h_{1M2} + h_{1M3} = \left(\frac{P_2}{\rho} + \frac{V_2^2}{2} + gz_2 \right) - \left(\frac{P_3}{\rho} + \frac{V_3^2}{2} + gz_3 \right)$$

$$\begin{aligned}
\rightarrow 0.002243 + 0.002301 \\
&= \left(\frac{80994}{1.20} + \frac{0.4724^2}{2} + (9.81)(0.15837) \right) - \left(\frac{P_3}{1.20} + \frac{0.4724^2}{2} - (9.81)(1.9801) \right) \\
\rightarrow 0.004544 &= (67495 + 0.11158 - 1.5536) - \left(\frac{P_3}{1.20} + 0.11158 - 19.4248 \right)
\end{aligned}$$

$$\rightarrow 0.008031 = 67493.6 - \frac{P_3}{1.20} + 19.3132$$

$$\rightarrow 0.008031 = 67512.9 - \frac{P_3}{1.20}$$

$$\rightarrow -67512.9 = -\frac{P_3}{1.20}$$

$$P_3 = 81015.5 \text{ Pa}$$

10.4.1.2.7 Results

As seen in section 3 above the calculations for both the clean hood and clean room at P_3 , the bottom of the units, result in a positive pressure above atmospheric pressure. Since the pressure is positive at the FFU's lowest speed settings this means that the medium speed and high speed settings will be sufficient enough to sustain the positive pressure. This analysis supports the client's requirement of the units producing and maintaining a positive pressure throughout use.

10.4.1.3 Fan Filter Unit Analysis

The purpose of the fan filter analytical report is to determine the capabilities of a High Efficiency Particulate Air (HEPA) fan filter. The client has requested a clean room for medical device testing, and a clean hood for operating their rheometer under, and they need to pass a clean room classification certification. This project will create a class certified clean room using at most two fan units, with a known cleanliness of the room, air velocity, air change rate (ARC), along with when to replace the filter. These are all factors that will play in the clean room classification.

10.4.1.3.1 Background

HEPA fan filters are used to filter out particles in the air, they are specially designed for use in cleanrooms and precision assembly areas [8]. These filters have an efficiency rating of 99.99% with particles 0.3 microns and larger in diameter [8]. They can be categorized into classes of cleanliness for a given number of particles in a given sized room. The classifications have two different ways of being rated, the International Standards Organization (ISO) and the U.S. General Service Administration's standards (known as FS209E) [9]. The FS209E contains six classes, while the ISO classification system has two cleaner standards and one dirtier standard. The "cleanest" cleanroom in FS209E is referred to as Class 1; the "dirtiest" cleanroom is a class 100,000. ISO cleanroom classifications are rated according to how much particulate of specific sizes exist per cubic meter. The "cleanest" cleanroom is a class 1 and the "dirtiest" is a class 9 [9]. The ISO class 3 is approximately equal to FS209E class 1, while ISO class 8 approximately equals FS209E class 100,000. Classifications will be done in the ISO format because it supersedes the FS209E standard as of 2014 [9].

10.4.1.3.2 Classification Effects

The client has specified they want a room that is 6'x8'x8', and a hood that is 2'x4'x4' and must maintain positive pressure. The classification plays a key role in the cleanliness of the room, air velocity, and the air change rate. Table 1 shows the effect of classification on these factors. The client mentioned the

cleanliness should be around an ISO class of 6-8. The difference between the ISO ratings is drastic in the number of foreign particles in the room as the rating number goes up.

Table 10. Classification Ranges for All Three Factors [9]

Class ISO 146144-1 (Federal Standard 209E)	Average Airflow Velocity m/s (ft/min)	Air Changes Per Hour
ISO 8 (Class 100,000)	0.005 – 0.041 (1 – 8)	5 – 48
ISO 7 (Class 10,000)	0.051 – 0.076 (10 -15)	60 – 90
ISO 6 (Class 1,000)	0.127 – 0.203 (25 – 40)	150 – 240
ISO 5 (Class 100)	0.203 – 0.406 (40 – 80)	240 – 480
ISO 4 (Class 10)	0.254 – 0.457 (50 – 90)	300 – 540
ISO 3 (Class 1)	0.305 – 0.457 (60 – 90)	360 – 540
ISO 1 – 2	0.305 – 0.508 (60 – 100)	360 – 600

The main factor is the velocity, for it directly affects the number of air changes per hour. The air change rate is the number of times per hour that “new” air is introduced into the system. The velocity affects the air flow in whether it is laminar for a longer time or becomes turbulent sooner. This directly affects the cleanliness, the sooner the flow turns turbulent the “dirtier” the air, with a laminar flow the speed and direction provide a uniform environment that prevents air pockets where foreign particles might collect [9].

10.4.1.3.3 Fan Filter Unit Calculation

The calculations for determining the total number of fan filter units (FFUs) was used to further define the classification of the project, respecting the clients need for a maximum of two FFUs. Equation 1 [9] and table 1 were used to calculate the number of fan units.

$$No. of FFUs = \left(\frac{Air\ Changes\ per\ Hour}{60} \right) * \left(\frac{ft^3\ of\ Room}{650^*} \right) \quad (1)$$

*CFM output of a loaded FFU

The cleanest ISO rating allowing for the full range of the listed air changes per hour in table 1, was an ISO rating of 7. This was calculated with the maximum ARC per hour of 90 and the room size of 6’x8’x8’ which is 384 ft³, the total number of FFUs calculated was 0.886, which can be rounded up to 1.00, as FFUs are sold as a single unit. With only numerically needing one FFU the client will potentially save money for the total cost of the project, having budgeted for the price of two units. For the ISO rating of 6 equation 1 was rearranged to calculate the maximum ARC per hour, which was 203, in which more than 2 FFUs would be required to produce the full range of ARC in an ISO class 6 environment.

$$Air\ Changes\ per\ Hour = \left(\frac{2}{\left(\frac{ft^3\ of\ Room}{650^*} \right)} \right) * 60 \quad (2)$$

The calculations for the hood were also produced using equation 1. An ISO rating of 1 was calculated with the maximum ARC of 540 per hour and the hood size of 2’x4’x4’ which is 32 ft³, the total number of FFUs calculated was 0.443, which can be rounded up to 1.00, creating an extremely clean work environment under the clean hood. The client plans to inter change the FFU between the clean room and hood, so this means the total required FFUs is still one.

10.4.1.3.4 Filter Replacement

Other than the need to know how many fan units can be used for the given dimensions of the room and the hood, the client also needs a way of knowing when to replace the filters in the FFUs. Fan filter units

have a total of three filters inside of them, a pre-filter, a bag filter, and the HEPA filter. The general agreement is that prefilters are to be changed roughly six times a year, bag filters are roughly changed every year, and HEPA filters are generally about three to eight years [10,11]. There are many different aspects that effect a HEPA filter and when it is changed, such as geographic or physical location of the building, nearby construction, proximity to freeways and commuter railroad tracks, as well as fog or other climate-related conditions [11]. They first year of changing filters is a trial period of observing when to change the filters [10,11].



Figure 1. 2'x4' FFU [12]

Figure 1 shows a 2'x4' FFU in which the blue pre-filter can be seen on top. Similar FFUs are to be purchased for this project's clear room/hood, and they will have the pre-filter, bag/box filter and the HEPA filter inside. The filters will be used in a laboratory on campus surrounded with lots of traffic, a train station close by, and a dry dusty climate. With these factors the client can do a trial year and observe the filters over time or they can try the other approach.

The other approach is to record the back pressure in the clean room/hood the first time it is used. Then when the back pressure in the clean room/hood has dropped by half the back pressure of the once new HEPA filter the filter is to be changed. This is because as the HEPA filter accumulates particles over its lifetime, pressure builds in the space between the blower and the HEPA filter [12]. If a HEPA filter accumulates too many particles and becomes clogged, it can result in a loss of efficiency that can compromise the cleanroom's ISO rating. If they are not replaced in a timely manner, severely clogged filters can destroy the motors in the Fan/Filter Units and potentially pose a fire hazard in the event of catastrophic electrical failure [12].

The purpose of this analytical report was to determine the capabilities of a High Efficiency Particulate Air fan filter. This was accomplished with the use of tabulated data displaying the ISO cleanliness classification, air velocity, and the air change rate, along with an equation for the number of fan filter units required for the size of the projects clean room and hood. The last method used to further determine the capabilities of a HEPA fan filter was to have an analytical method for when the HEPA filter was to be replaced. From the results found it was determined that the client will only need one FFU for his needs, and the initial back pressure will need to be recorded and checked for loss in back pressure to safely operate the system.

10.5 Computational Fluid Dynamics Analysis – Fluid Visual

Representation

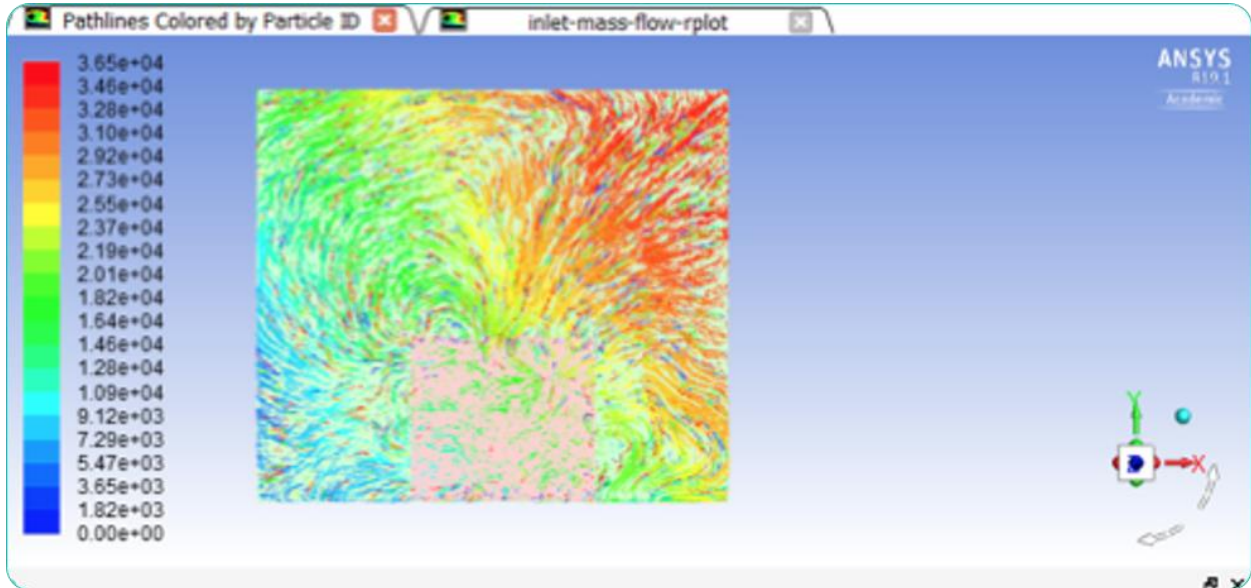

10.6 Appendix E: Bill of Materials

Bill of Materials Clean Dream Team						
Portable Hood						
Part #	Part Name	Qty	Description	Functions	Material	Dimensions
1	Aluminum Frame	6	Hood Frame DONATED -98C	Supports Fan	Aluminum	1"X 1/8"
2	Polycarbonate	1	For 3 sheets Material For Hood	Creates converging for hood	Polycarbonate	48"x48"
3	Cut Polycarbonate	1	Cut the polycarbonate	Is the inner shell of the hood	Polycarbonate	48"x48"
4	Epoxy	3	seals the polycarbonate	creates a seal for no air to escape	Plastic	n/a
5	Rubber lining	1	cushions FFU to frame	to prevent air leakage between frame and FFU	Rubber	19/32"
6	Magnets	1	Holds door	Keeps door open for ease of adjustments within hood	Neodymium	1/2 dia
7	Machine Screws	1	tightens hinges	secures the hinges	Zinc plated	32x1/2
8	Ardrino	1	Test Pressure within Unit	To test Pressure within unit	N/A	
9	Power Cord	1	Power the FFUs - 3 wire power tool replacement cord	Power the FFU	N/A	
9	Hinges	1	hinges for hood	allows the hood door to open	Zinc plated	2-1/2"
Portable Room						
Part #	Part Name	Qty	Description	Functions	Material	Dimensions
10	Steel Frame	125	Steel - 110' - 2"x2"x1/8"	Framing for the portable room	steel	2"x2"x1/8"
11	White Powder Coat	110	Powder coat the steel frame	Protect the steel and to reduce particals released by the steel	Powder coat	
12	Plastic Sheeting Roll	1	Plastic to Wrap Room	Creates covering for room	Plastic	54"x60'
13	DuraGrip Brand Adhesive Back	4	Adhesion for plastic Wrap	Holds plastic wrao in place	Velcro	1"x75"
14	Steel Joints	16	Joints to support Frame	Supports frame	Steel	n/a
15	Shear Pins	4	Holds legs in place	Help adjusting size of room	steel	2.75"x6"
16	Power Cord	1	Power the FFUs - 3 wire power tool replacement cord	Power the FFU	N/A	
17	Heavy Duty Swivel Caster Wh	4	600lb capacity swivel caster wheels - DONATED	Allows for the portable room to be stationary and mov	5 x 1-1/4 in nylon poly	Wheels
	Not Purchased					

10.7 Appendix F: Gantt Chart

Capstone: Clean Room Gantt Chart

